

**FRDC FINAL REPORT**

PRELIMINARY INVESTIGATION  
TOWARDS ONGROWING PUERULUS TO  
ENHANCE ROCK LOBSTER STOCKS  
WHILE PROVIDING ANIMALS FOR  
COMMERCIAL CULTURE

*Caleb Gardner, David Mills, Sam Ibbott, Simon  
Wilcox and Bradley Crear*

*June 2000*

*FRDC Project No.1999/314*



F I S H E R I E S  
R E S E A R C H &  
D E V E L O P M E N T  
C O R P O R A T I O N



Tasmanian Aquaculture  
& Fisheries Institute  
*University of Tasmania*

**National Library of Australia Cataloguing-in-Publication  
Entry**

Gardner, C. (Caleb), 1968-

Preliminary investigation towards ongrowing  
puerulus to enhance rock lobster stocks  
while providing animals for commercial  
culture.

Bibliography.

Includes index.

ISBN 0-7246-4761-9.

1. Spiny lobsters-Tasmania. 2. Lobster  
fisheries – Tasmania-Management. #.  
Marine resources – Tasmania-  
management. I. Gardner, C. (Caleb), 1968 -.  
II. Tasmanian Aquaculture and Fisheries  
Institute. III. Title: FRDC Project no.  
1999/314. (Series: Technical report series  
(Tasmanian Aquaculture and Fisheries  
Institute); no. 13).

639.54109946

Published by the Marine Research Laboratories - Tasmanian  
Aquaculture and Fisheries Institute, University of Tasmania  
2000

Series Editor - Dr Caleb Gardner

The opinions expressed in this report are those of the author/s  
and are not necessarily those of the Marine Research  
Laboratories or the Tasmanian Aquaculture and Fisheries  
Institute.

# FRDC FINAL REPORT

Preliminary investigation towards ongrowing puerulus to enhance rock lobster stocks while providing animals for commercial culture

*Caleb Gardner, David Mills, Sam Ibbott, Simon Wilcox and Bradley Crear*

*April 2000*

*FRDC Project No.1999/314*



F I S H E R I E S  
R E S E A R C H &  
D E V E L O P M E N T  
C O R P O R A T I O N



Tasmanian Aquaculture  
& Fisheries Institute  
*University of Tasmania*



## 1. Project Summary

<b>99/314</b>	<b>Preliminary investigation towards ongrowing puerulus to enhance rock lobster stocks while providing animals for commercial culture</b>
---------------	-------------------------------------------------------------------------------------------------------------------------------------------

**PRINCIPAL INVESTIGATOR:** Dr Caleb Gardner  
**ADDRESS:** University of Tasmania  
Tasmanian Aquaculture and fisheries institute  
Marine Research Laboratories  
Nubeena Crescent  
Tarooma TAS 7053  
Telephone: 03 62277233 Fax: 03 62278035

### OBJECTIVES

1. To develop methods to capture large numbers of 1 year old benthic juvenile rock lobsters, both for providing control animals and for monitoring survival of reseeded animals.
2. To determine the extent of movement of on-grown and control juveniles after release to assist estimation of survival.
3. To develop methods to assess relative survival of cultured juvenile lobsters released into a natural habitat.

### NON TECHNICAL SUMMARY

The potential benefits from reseeded juvenile rock lobsters back to the wild are broad. In the short term, it will allow the commencement of commercial rock lobster aquaculture operations in Tasmania through the harvest of puerulus (first settling stage of juvenile rock lobsters). A concern with the harvest of puerulus is that catch of rock lobsters is effectively increased. Successful reseeded of juvenile rock lobsters provides a mechanism for biological neutrality in the harvest of puerulus as a percentage of juveniles can be reseeded to the wild after one year of on-growing. When this percentage is greater than natural survival over the same period, the harvested puerulus are replaced and a level of fishery enhancement is achieved.

Reseeded of juvenile rock lobsters may also be an effective tool in the enhancement of coastal reef by shifting lobsters from areas of high larval settlement, but low productivity, to areas with higher productivity. In the longer term, if hatchery production of puerulus becomes viable, large-scale enhancement of the wild fishery may be possible.

The extent of any benefits from reseeded juveniles are dependent on the survival of released juveniles. Survival of reseeded juveniles may differ from that of wild juveniles as they may be more vulnerable to predation or have less ability to locate and compete for food and shelter resources.

Little is known about movement, behaviour or survival of the early juvenile stages of southern rock lobster in the wild. Difficulties in capturing this life history stage have limited research opportunities. Accordingly, this preliminary project did not aim to quantify survival of reseeded juveniles, but rather develop methods for accurately assessing survival of reseeded lobsters relative to wild lobsters.

Research effort was directed to developing capture methods for wild lobsters of 30mm to 50mm carapace length (approximates 1 year old post-settlement), for use as experimental controls. Seventeen trap designs were tested ranging from standard commercial lobster, crab and fish traps, to specifically designed traps based on known behaviour of juvenile southern rock lobster. Only trammel nets showed any ability to catch juvenile lobsters, however bycatch was extensive and the effort involved in cleaning and maintaining nets was excessive. Various baits were compared in a specifically designed 'Y' tank, with lobsters observed by camera under infra-red light. No baits capable of attracting juvenile lobsters to traps were identified. Diver capture of juvenile lobsters proved more efficient than anticipated and was the most economical method of collection.

Movement patterns were assessed by attaching miniature acoustic transmitters to lobsters on-grown from puerulus and wild lobsters, to track movement over periods of up to 21 days. Nine lobsters were released on an area of patch reef near Hobart on two occasions. On-grown lobsters immediately moved into appropriate shelters or dens, often cohabiting with wild lobsters. Avoidance behaviour toward divers (and thus large predators ?) appeared well developed. Most movement was confined to within an area 32m x 32m centred on the release site. All lobsters were recaptured after 14 days, and stomach contents revealed similar feeding rates between wild and on-grown lobsters.

Separating loss of animals from a study area due to mortality, and loss due to emigration is problematic in survival studies (have they died or just waked away ?). We tried to overcome the problem of movement biased survival estimates with two approaches. The first, called "the Jackson Square technique" measures movement within a search area to estimate movement away from the search area.

The second approach was to attempt to survey such a broad area that emigration out of the search site was minimal. This approach reduced the risk of animals emigrating from the search area but potentially increased the risk of missing animals that were present. Analysis in the second approach was by multi-strata Cormack Jolly Seber modeling which permits estimation of parameters for different spatial areas. Most importantly for this study, we could obtain estimates of the probability of divers missing an animal that was alive and in the area they searched, for different spatial areas. As a result we could "factor-in" the reduced efficiency of infrequent diver searches of reef that were a long way from the release site.

Our ability to estimate the survival of reseeded juveniles was assessed in a large scale release using antennal-tagged juvenile lobsters which had been reared in captivity for a year since capture as puerulus, and wild-caught controls (427 on-grown, 153 wild-caught). These were released onto a 32m x 32m Jackson square grid on reef. Divers recorded lobster sightings and positions in the grid and on adjacent reef on 9 occasions over the following month. Transect searches of reef up to 800m away from the release site, performed on 3 occasions, showed lobsters had moved considerably further than anticipated from acoustic tracking results, and that on-grown lobsters moved further than controls. These unexpected results implied that survival estimates using the Jackson square method would not be valid.

We found that the multistrata model was more robust for measuring survival of juvenile rock lobsters as it allowed some flexibility in extending the sampling area to cover all habitat being used by the reseeded juveniles. Divers could follow natural reef contours to optimise their chance of resighting juveniles, rather than be constrained by the geometric grid of the Jackson square.

Estimates from the multistrata model confirm higher rates of movement by on-grown lobsters, but only in the first 2 days following release. The survival estimate of 95% was the same for both on-grown and control lobsters, and did not vary between sampling areas or across time. This should be considered a conservative estimate of survival (ie the actual figure may be higher), as it may retain an emigration bias, and has not been adjusted for tag loss. Both these factors would tend to bias the survival estimate lower.

Our survival results are encouraging for the future of reseeded, however we urge caution in their interpretation. There is evidence that survival varies greatly between habitats and/or regions, and seasonal effects are also likely. Most importantly, this study has shown that obtaining accurate estimates of short-term survival of juvenile lobsters is both possible and practical. We are confident that results from the model, and new knowledge on juvenile lobster movement can be used to design a robust study to predict likely survival of reseeded lobsters across habitats, geographic regions and seasons.

**KEYWORDS: southern rock lobster, survival, enhancement, aquaculture**

# Table of Contents

<b>1. PROJECT SUMMARY.....</b>	<b>I</b>
<b>2. BACKGROUND .....</b>	<b>1</b>
<b>3. NEED.....</b>	<b>2</b>
<b>4. OBJECTIVES .....</b>	<b>3</b>
<b>5. COLLECTION AND TAGGING TECHNIQUE DEVELOPMENT .....</b>	<b>3</b>
5.1 LOBSTER TRAP TRIALS.....	3
5.1.1 Methods.....	3
5.1.2 Results.....	4
5.2 BAIT ATTRACTION TRIALS.....	5
5.2.1 Methods.....	5
5.2.2 Results.....	7
5.2.3 Discussion.....	8
5.3 LOBSTER CAPTURE BY DIVERS .....	8
5.4 ANTENNAL TAGGING.....	8
5.4.1 Tag construction.....	8
5.4.2 Re-sighting tags.....	9
5.5 MINI T-BAR TAGGING.....	9
<b>6. STUDY SITES AND PERIOD .....</b>	<b>9</b>
6.1 RESULTS AND DISCUSSION .....	10
<b>7. MOVEMENT .....</b>	<b>12</b>
7.1 SONIC TAGGING EQUIPMENT AND FIELD METHODS FOR ACOUSTIC TRACKING.....	12
7.1.1 Acoustic transmitter tags .....	12
7.1.2 Boat-mounted tracking apparatus .....	13
7.1.3 Diver-held receiver.....	14
7.1.4 Acoustic tracking protocol by divers.....	15
7.1.5 Tank trials of acoustic tagging method.....	15
7.1.6 Field trial of tagging and tracking methods.....	16
7.1.7 Study design and field methods for movement experiments .....	17
7.1.7.1 Acoustic tag experiments.....	17
7.1.7.2 Visible tag experiment.....	18
7.2 RESULTS OF MOVEMENT RESEARCH .....	18
7.2.1 Practical observations on the technique of acoustic tracking.....	18
7.2.2 Daily movement patterns.....	20
7.2.2.1 Sonic release 1 .....	20
7.2.2.2 Sonic release 2 .....	21
7.2.2.3 Sonic release 3 .....	22
7.2.3 The effect of group on movement patterns.....	22
7.2.3.1 Sonic tracking data.....	22
7.2.3.2 Antennal tagging results .....	23
7.2.4 Density dependent effects on movement.....	25
7.3 DISCUSSION IN RELATION TO ESTIMATING SURVIVAL IN JUVENILE LOBSTER RESEEDING.....	27
<b>8. FEEDING BY ON-GROWN JUVENILES.....</b>	<b>28</b>
<b>9. RESEEDING EXPERIMENT.....</b>	<b>29</b>

9.1 ANALYTICAL METHODS FOR SURVIVAL ESTIMATION.....	29
9.1.1 The Jackson Square technique.....	29
9.1.2 Multi-strata mark-recapture estimates of survival for on-grown and control juveniles.....	31
9.1.3 Summary of practical differences and assumptions in Jackson Square and Multi-strata techniques.....	34
9.2 STUDY DESIGN AND FIELD METHODS.....	36
9.3 JACKSON SQUARE RESULTS .....	39
9.4 MULTI-STRATA MODELING RESULTS.....	39
9.4.1 Goodness of Fit testing.....	39
9.4.2 GOF Results.....	40
9.5 MODEL SELECTION.....	43
9.5.1 Models fitted and hypothesis process.....	43
9.6 RESULTS OF MULTI-STRATA TAG-RECAPTURE MODEL.....	46
<b>10. BENEFITS.....</b>	<b>48</b>
<b>11. FURTHER DEVELOPMENT .....</b>	<b>49</b>
<b>12. CONCLUSION .....</b>	<b>50</b>
<b>13. REFERENCES .....</b>	<b>51</b>
<b>14. APPENDIX 1 - INTELLECTUAL PROPERTY.....</b>	<b>52</b>
<b>15. APPENDIX 2 - STAFF.....</b>	<b>52</b>
<b>16. APPENDIX 3 - BYCATCH SPECIES .....</b>	<b>54</b>
<b>17. APPENDIX 4 - LOG REPORTS OF AREAS SURVEYED FOR SUITABLE TRACKING AND RELEASE SITES.....</b>	<b>55</b>



## 2. Background

Until hatchery methods of producing lobster puerulus are developed, wild-grown puerulus must be viewed as a finite and valuable component of the rock lobster fishery resource. The efficiency of the wild fishery lies in the fact that there is no investment in individual lobsters prior to harvest, although survival of puerulus through to harvest is low. Methods of increasing survival to a marketable product have the potential to significantly improve the yield from this resource through both enhancing the wild harvest and through aquaculture.

Survival through the first year of life in the wild is low (estimated at between 3% and 25% for temperate species, and as low as 3% for tropical species). First year survival of puerulus removed from the wild into culture is far higher (eg 93% to 99%, Crear *et al.* 1998). Following culture through this high mortality period, there are 2 options for producing a marketable product: ongrowing in culture; or reseeding wild populations for future harvest. If lobsters are retained for culture, there is a net loss to the fishery. This loss can be fully compensated by releasing, after a year of culture, the equivalent number of juveniles that would have survived in natural conditions. Any additional juveniles released above this base level should act to enhance the fishery - so that it becomes possible to both enhance the wild fishery and retain some animals for ongrowing in intensive culture.

Fishery enhancement research with hatchery-reared clawed lobsters in the United Kingdom and Norway have resulted in large numbers surviving through to the fishery and adding to the spawning biomass (Bannister 1998, van der Meeren 1998). As much as 60% of commercial catch in parts of Norway comprises reseeded lobsters (Tveite and Grimsen 1995, K. Jørstad 1999-CSIRO seminar series). The potential for this enhancement benefit to be replicated in Australia is dependent on the ability of on-grown juveniles to survive following release. Predation of reseeded juveniles, and inability to compete with wild juveniles for food and shelter resources, are potential threats to survival.

For successful reseeding to occur, it will be necessary to identify factors affecting survival, and to minimise their impact through development of appropriate methods of pre-release culture, release habitat selection, and release technique. These issues are relatively complex and their research relies on the ability to measure survival of reseeded juveniles in the field - the subject of the research described here. This preliminary research will establish the feasibility of techniques to assess the survival of reseeded juveniles in the field over short periods of up to 1 month, which is important before embarking on any broader projects.

### 3. Need

Information on the survival of reseeded juveniles is required to assess the economic viability of any reseeded operation including:

- the release of juveniles to compensate for puerulus harvest;
- the release of hatchery produced juveniles for enhancement;
- shifting rock lobsters between different areas to increase productivity.

An immediate need for information on the survival of reseeded juveniles in Tasmania where the development of an aquaculture industry based on puerulus harvest is expected to commence over the next year. A rock lobster aquaculture industry based on the harvest of puerulus from the wild cannot proceed if there is a net loss of animals from the wild fishery. The concept of removing puerulus from the wild has received widespread opposition from participants in rock lobster fishing industries, and managers of the resource. Rock lobster fisheries management policy in most states is specifically directed towards stock rebuilding and it is perceived that additional extraction by puerulus removal runs counter to those policies.

Current research on techniques for the extraction and on-growing of puerulus from the wild have proceeded with an assumption that puerulus extraction should be 'biologically neutral'. It has been proposed that 'biological neutrality' can be achieved by a proportional reduction in catch of adult animals, either through a reduction in effort (eg removal of pots) or through buy-out of quota (in ITQ management). However, this mechanism for achieving biological neutrality has been criticised, as puerulus extraction is likely to occur in sheltered, heavily exploited regions - while the effort removed from the fishery may have been directed to a completely different region. In this scenario, puerulus extraction could lead to local depletion and loss of egg production, despite the concurrent reduction in effort.

The proposed project is directed to an alternative mechanism for compensating for the removal of puerulus. Reseeded animals can be released back to the same areas from which they were extracted so no localised depletion will result. Reseeding the area with animals additional to those required for biological neutrality will provide an enhancement benefit. This system has benefits to the fishing industry through enhanced yield, and also to the proposed aquaculture industry through access.

The potentially valuable on-growing industry is reliant upon the development of a mechanism for compensating for puerulus harvest that does not harm the wild fishery.

## 4. Objectives

Objectives were unchanged from those proposed in the application. Three objectives were proposed and were intended to focus the project on the development of methods for assessing survival.

1. To develop methods to capture large numbers of 1 year old benthic juvenile rock lobsters, both for providing control animals and for monitoring survival of reseeded animals.
2. To determine the extent of movement of on-grown and control juveniles after release to assist estimation of survival.
3. To develop methods to assess relative survival of reseeded juvenile lobsters released into a natural habitat.

## 5. Collection and tagging technique development

### 5.1 Lobster trap trials

#### 5.1.1 Methods

Juvenile lobsters have typically proven difficult to trap by conventional methods. Few lobsters of less than 65mm carapace length are captured in commercial lobster pots, even with the escape gaps tied (for research catch sampling). In an attempt to devise an efficient method of catching large numbers of early benthic phase lobsters (carapace length 35-50mm) to be used as control animals, capture methods falling broadly into 4 categories were tested. The majority of the traps rely on attracting lobsters to a bait, and the ability of the trap to retain the lobster once it has been attracted. A second group, termed 'casitas' (Spanish for 'apartment') were based on the successful trap designs used for spiny lobsters in the Caribbean (Miller 1982, Mintz *et al.* 1994). These provide habitat for lobsters and are regular in design which makes lobsters easier to catch. The third group (trammel nets) rely on entanglement of lobsters as they move. The fourth method tested was hand capture by divers.

Traps/nets tested included:

- Conger eel trap
- Steel frame catch sampling pot with fine nylon mesh
- Stick lobster pot covered with fine wire mesh
- Square crab trap
- Dome traps
- Starfish traps – developed for *Asterias amurensis*

- Opera house traps
- Scampi trap
- Square type nylon trap
- Polynesian fish trap
- Collapsible mesh crab traps
- Wooden 'casita' traps
- Brick 'casita' traps
- Cotton trammel net
- Nylon trammel net

Traps requiring bait attractants were initially baited with Jack mackerel (*Trachurus declivis*) and Barracouta (*Thyrsites atun*) which are standard bait types when fishing for mature lobsters. These baits were unsuccessful so blacklip abalone (*Haliotis rubra*) was also tested, without success. Crushed mussels (*Mytilus edulis*) which show strong attractant properties in a tank environment (Crear *et al.* 1998) were also unsuccessful.

Juvenile lobsters are gregarious once they have undergone an ontogenetic shift from a solitary phase at around 35mm carapace length (Edmunds 1995). We attempted to utilise this gregarious behaviour by using live conspecifics, tethered into the back of the 'casita' type traps, to act as bait. Again this method was unsuccessful, as was a combination of conspecifics and crushed mussels.

All traps were set in areas with high densities of juvenile lobsters, as confirmed by diver inspection. During some trials the traps were hand placed by divers within short foraging distance of occupied juvenile lobster dens.

### 5.1.2 Results

Of the 17 trap methods tested, all caught animals, and the bycatch list is extensive, comprising fish, echinoderms and crustaceans (appendix 3). Only trammel nets caught juvenile lobsters. Initially, 'off-the-shelf' cotton trammel nets (external mesh; 35cm (stretched), internal mesh; 9cm, drop; 1.5m) were tested. Bycatch from these nets was considered excessive. Net drop was reduced to approximately 30cm but bycatch remained high and sorting this from nets was time consuming. Nylon mono-filament trammel nets were less effective than the cotton nets. The effort involved in clearing and maintaining trammel nets was considerably greater than the effort of diving to collect the same number of lobsters by hand.

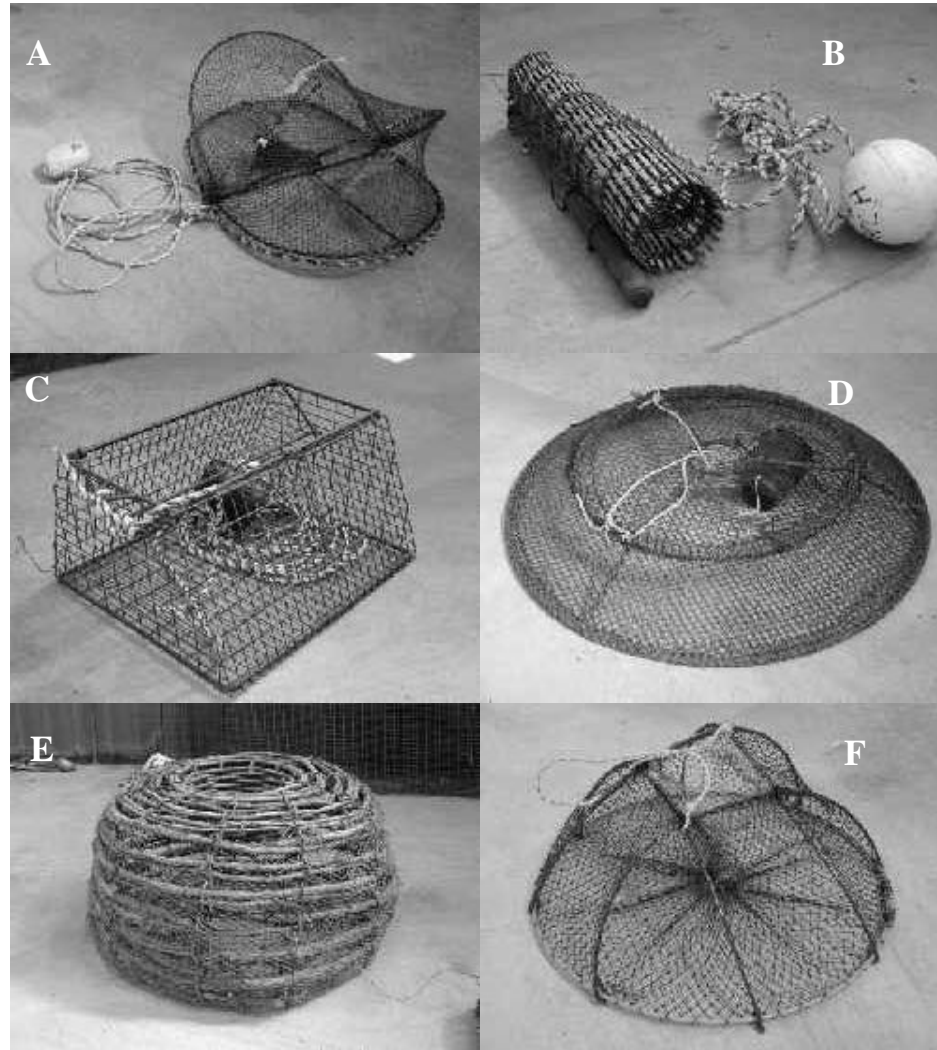

**Figure 1.** Selection of traps tested for capture of juvenile lobsters: A - Opera House trap; B - Polynesian fish trap; C - Square crab trap; D - modified starfish trap; E - meshed stick lobster pot; F - dome trap

## 5.2 Bait attraction trials

### 5.2.1 Methods

Experimentation with trap design was augmented by experiments on the attractiveness of different baits using a ‘Y-tank’ choice design (Figure 2). Water flows through the ‘arms’ of the ‘Y’, across a different bait placed in each arm. A ‘scent plume’ from each bait is carried into the central arm of the ‘Y’, and lobsters released at the base of the central arm will likely follow the most attractive plume to locate the attractive bait.

The Y-tank was set up with water depth of 12 cm and total flow rate of  $5 \text{ lmin}^{-1}$  ( $2.5 \text{ lmin}^{-1}$  at each inlet). Water was at ambient temperature and was pumped directly from the Crayfish Point Scientific Reserve, Derwent Estuary, Southern Tasmania. The base of the tank was

lined with clean pebbles varying from 1 to 4 cm diameter. The flow regime in the tank was observed by introducing food-dye coloured milk with a hypodermic syringe to the points where baits would be placed. An acceptably linear flow was observed throughout the 'arms' of the tank, with only slight turbulence created at the junction of the arms. Mixing of the two plumes from the arms was observed in an area about half way down the central arm of the tank.

All trials were conducted at night, as lobsters are nocturnal feeders. An infra-red light source (Pelco 12V IR light bank) was placed over each arm of the tank, giving sufficient illumination to see lobsters clearly from when they emerged from the holding area. Spiny lobsters are insensitive to infra-red light (Meyer-Rochow & Tiang 1984) so this system allowed us to observe lobsters behaving as if under full darkness. An infra-red sensitive security camera was supported above the tank, and was linked to a video recorder. The recorder was set on 'slow record', which provides 8hrs of footage from a 4hr tape. The video also recorded a continuous 'time-stamp' to allow events to be related directly to time. Videos were reviewed on fast-forward giving about four times normal play-back speed.

Three baits were tested: abalone gut; crushed mussels; and jack mackerel. Approximately 100g of each bait was encased in chicken-wire to ensure large pieces of bait could not be moved by water flow or lobsters, but allowing easy feeding by lobsters. Three replicate trials of each pair of baits were completed, giving a total of nine trials. Trials were conducted over a two week period, and the sequence of trials randomised.

Lobsters for the trials were obtained from the wild and held unfed in the Y-tank for 48hrs prior to introducing baits, to allow acclimation to the tank. Three lobsters were used for each trial, and lobsters were replaced after two trials. After each trial the tank was scrubbed, and pebbles were removed from the tank and washed in seawater.

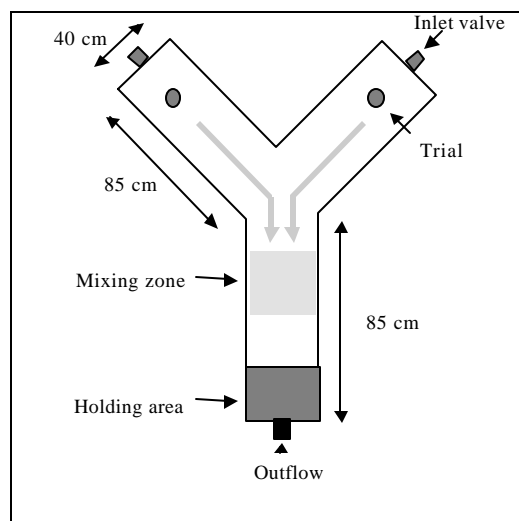

**Figure 2.** 'Y' tank set-up for bait comparison trials.

### 5.2.2 Results

Results from Y tank trials were largely inconclusive, as activity levels were low, behaviour patterns inconsistent, and there was little evidence of feeding at any stage during the trial. An example trace of movement (Figure 3) illustrates some patterns common in several trials. Two of the three lobsters moved during the trial period. Trace 'A' shows movement towards the mussel bait, stopping regularly for periods of up to ten minutes. Movement is largely along the sides of the tank, or at a distance where antennal contact with the tank wall is maintained.

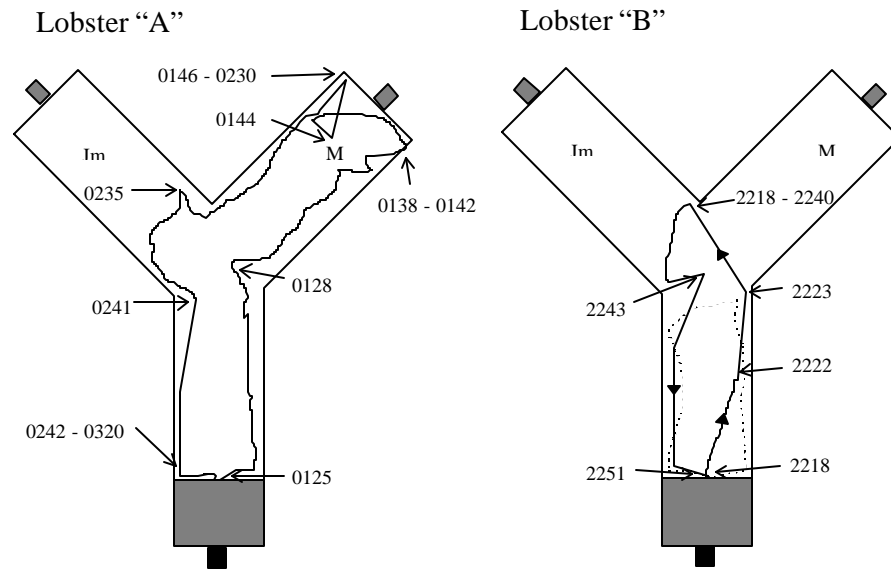

**Figure 3.** Trace of movement of two lobsters (A and B) in trial of mussel (M) against jack mackerel (Jm). Lobster B undertook 2 excursions, the second shown by the discontinuous line. Times are given for excursion 1 only. Trials commenced at 1800 with lobsters being released from the holding area and baits added.

Lobster B does not move into either arm of the tank in two excursions. Lobsters often 'settled' in corners of the tank for substantial periods of time, but there was no consistency in location of settling relative to baits.

Throughout the trials, multiple excursions by individual lobsters were frequent, but there was little consistency in direction of movement or behaviour. While approximately 50% of lobsters visited one or other of the baits during excursions, time spent at the baits was no greater than time spent at other locations around the tank. It appears likely that observed movement in most or all cases was 'exploratory' rather than a response to presence of attractive baits. Within the resources of this project, it was not practical to extend the range of baits or number of replicate trials.

### 5.2.3 Discussion

The ineffectiveness of traps relying on bait attractants may be due to the baits used, rather than trap design. The three baits tested are known to be eaten by lobsters. Crushed mussels are the 'control' food source used for juvenile lobsters in culture (Crear et al 1998), and growth rates on mussel diet are high. However, observations of culture tanks suggest that there are times when lobsters will not feed on mussels. Feeding behaviour may be dependant on water temperature. A concurrent study of adult lobsters in the Derwent Estuary has shown they are less likely to enter traps during the winter months when these bait trials were conducted (P. Ziegler, T.A.F.I. - pers. com.). Seasonal trials of bait effectiveness would be required to test this theory. Ideally trapping and Y-tank trials would be repeated in summer, however such trials fall outside the scope of this study.

### 5.3 Lobster Capture by Divers

While traps were largely unsuccessful, diver capture of juvenile lobsters proved more efficient than anticipated.

Control lobsters were collected by hand, with divers selecting lobsters of 35 - 50 mm carapace length before removing them from their den. These juvenile lobsters could be prevented from retreating into their den by placing a dive knife behind them, before they were extracted by the horns, generally without damage. Throughout the project this technique was quite successful in a variety of habitats, with a two person dive team catching up to 130 lobsters in one day.

### 5.4 Antennal tagging

To track lobster movement following a large-scale release, a method of tagging which allowed visual identification of individual lobsters was required. Within a den, lobsters will invariably face towards the nearest opening, allowing them to observe to approach of potential predators. Accordingly, tags had to be visible from the front of the lobster without obscuring the lobsters' vision. As antennal flagella are easily shed, and attachment to legs would hinder movement, it was considered that the antennal bases ('horns') were the most appropriate attachment point.

#### 5.4.1 Tag construction

Tags were constructed from 12cm lengths of 0.75mm diameter copper wire, and small coloured beads of approx. 2mm diameter. The wire was crimped at one end, and up to 5 coloured beads (black, white, blue, orange, yellow) were threaded onto the wire in unique colour combinations. The wire was again crimped behind the beads to hold them in place. Black beads were used as a unique identifier for control (wild-caught) lobsters, and were always placed first on the wire.

Tags were applied to lobsters by wrapping the copper wire tightly around the right antennal base 4 -6 times. Tag retention experiments were conducted in tanks over a period of 2 weeks and used to refine the application process.

#### 5.4.2 Re-sighting tags

Despite the use of torches, some divers expressed difficulties in differentiating between white and blue beads, and white and yellow beads once underwater. Careful selection of bead colours, including underwater trials with divers using torches, is important to maintain data integrity. Particular note of trial results should be taken when divers have any degree of colour blindness.

Confusion between treatment groups was not a problem due to the black bead placed on all control tags.

### 5.5 Mini T-bar tagging

Tags which are not shed at moult will be required for longer term survival studies. T-bar tags have been successfully used in adult *J. edwardsii* in Tasmania since 1973 (Kennedy, 1986). Tag mortality and shedding rates are low, and tags are easily detected when lobsters are handled by fishers. While standard T-bar tags are too large for use on juvenile lobsters, mini T-bar tags may be suitable, the tag and the applicator needle both being significantly smaller.

Forty lobsters were tagged by inserting Hallprint mini T-bar anchor tags ventrally in the first abdominal segment. Thirty tags were inserted adjacent to the lateral line, while a further 10 were inserted to the lateral extreme of the segment, resulting in the tag protruding from under the lobster carapace behind the last leg. Lobsters were held for 3 months in a 4m<sup>3</sup> tank containing several concrete blocks to provide shelter.

Within one month post-tagging, 5 lobsters died and 2 shed tags. Significant tissue necrosis was evident in 4 of the 5 mortalities. Tag loss occurred at moult in both cases. While no further mortalities or tag losses were recorded, a further 5 lobsters exhibited varying degrees of non-fatal necrosis. All appeared to be healing at the conclusion of the study. It is possible that the use of antibiotic/antifungal paste in the tagging operation would decrease the incidence of tissue necrosis.

Tag position appeared to have no effect on either tag loss or mortality.

## 6. Study sites and period

A comprehensive dive survey of inshore coastal reef was conducted in waters adjacent to the Marine Research Laboratories, TAFI. The aim of the survey was to find areas of reef suitable for acoustic tracking, release trials, and as collection areas for control lobsters. To maximise the effectiveness of acoustic tracking, a reef with relatively low relief and low macro-alga

cover was required. Similarly, habitat consisting of small, relatively uniform boulders would make the process of laying a regular search grid easier, and would simplify the search process. As there was no prior information on likely scales of movement of juvenile lobsters, it was considered important that initial trial releases take place on an area of patch reef preferably surrounded by sand, providing a degree of natural containment of lobsters. The presence of wild juvenile lobsters on the site was considered important, as evidence of the presence of appropriate food and shelter.

## 6.1 Results and Discussion

Twenty seven sites in the D'Entrecasteaux Channel, Derwent Estuary and Fredrick Henry Bay were surveyed by divers (Figure 4). Brief descriptions of sites, habitat types and lobster abundance are presented in Appendix 4.

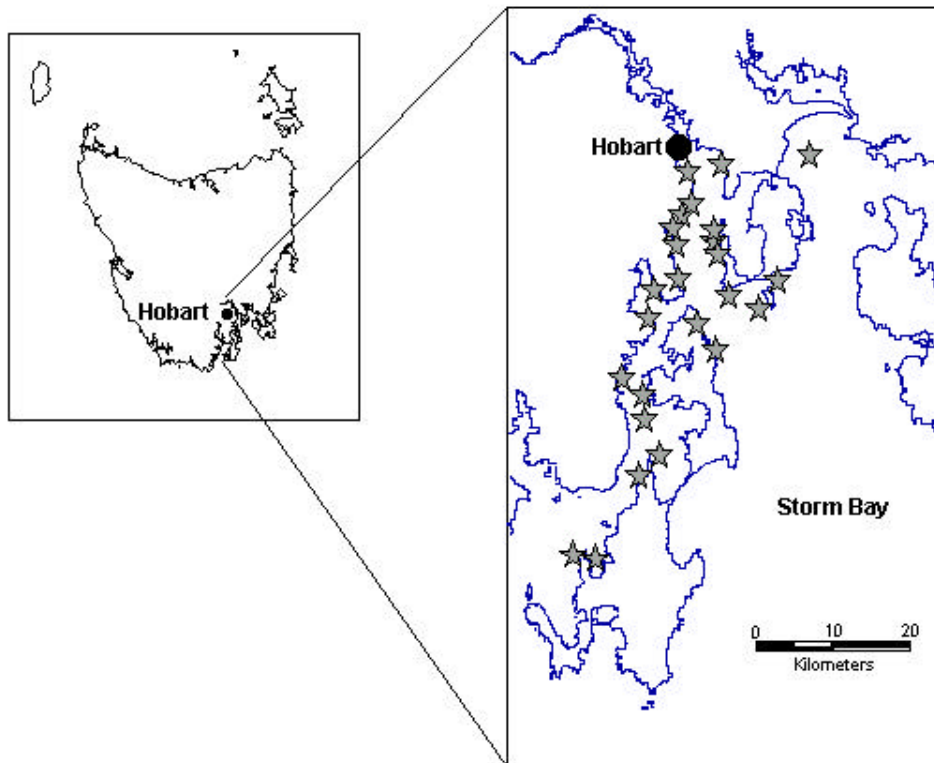

**Figure 4.** Sites surveyed in the D'Entrecasteaux Channel, Derwent Estuary and Fredrick Henry Bay for suitability as trial release sites.

A site near South Arm in the Derwent Estuary, Southern Tasmania (Figure 5 and Figure 6) was selected as the most appropriate for acoustic tracking and large scale release experiments. The reef at this location was approximately 150 m NW of Glenvar Point, in 7m of water. The maximum rise of the reef from the sea floor was approximately 2m. The reef covered an area of approximately 2500 m<sup>2</sup> and consisted of sandstone and dolerite boulders

of small to moderate size, on a sandstone substrate. The reef was bordered by sand on its western boundary, and an unstructured flat sandstone platform on other sides.

A video survey of this area conducted in 1998 revealed a high abundance of newly settled juvenile lobsters, confirming the suitability of this habitat, and the potential for a large carrying capacity. The current survey revealed low numbers of recently settled juveniles, but moderate abundances of juveniles of 30 to 50 mm carapace length.

Areas of near-shore reef north of the chosen site were judged suitable for collection of control lobsters and trap trials, but were unsuitable for release of acoustic tracking due to high-relief and complex reef structure.

An area in Bicheno, on the east coast of Tasmania (Figure 5) was selected for a further acoustic tracking trial. This site was chosen for contrast to the Glenvar Point site. The site comprised extensive granite reef in approximately 6m of water. Macro-algal cover was considerable, and relief was up to 4.5m. Predator abundance was considered to be high, as the reef borders the Governor Island marine reserve.

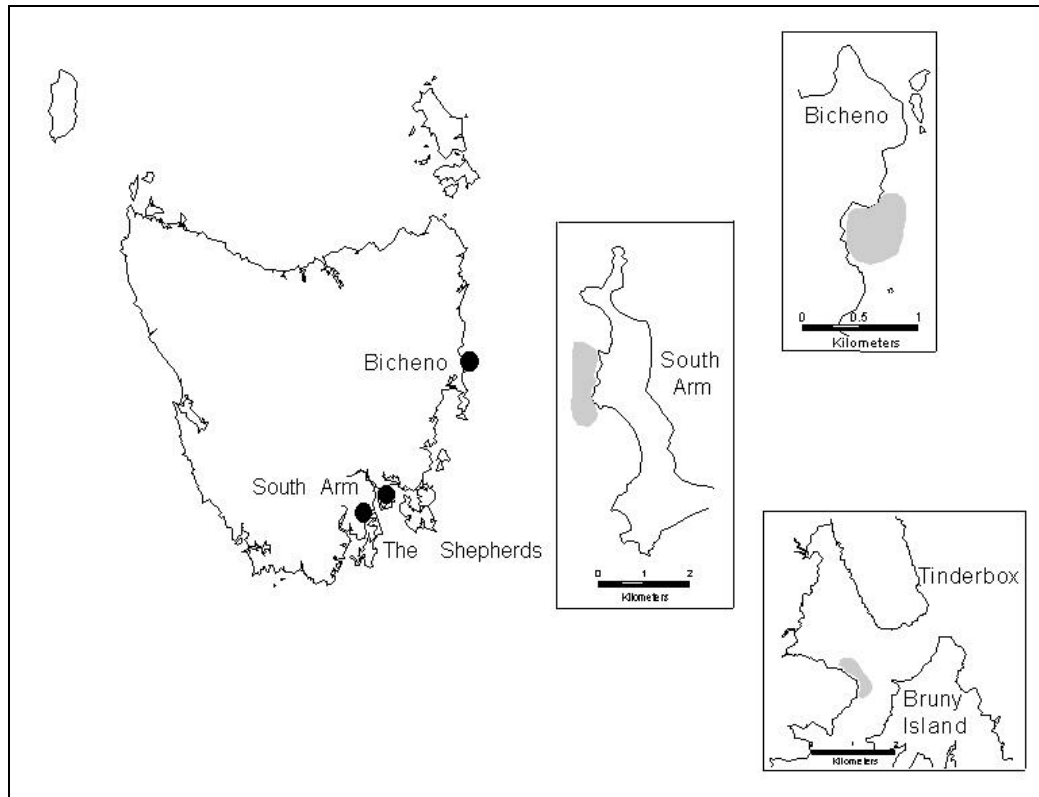

**Figure 5.** Location of lobster release areas around Tasmania. Areas searched during tracking operations are shaded.

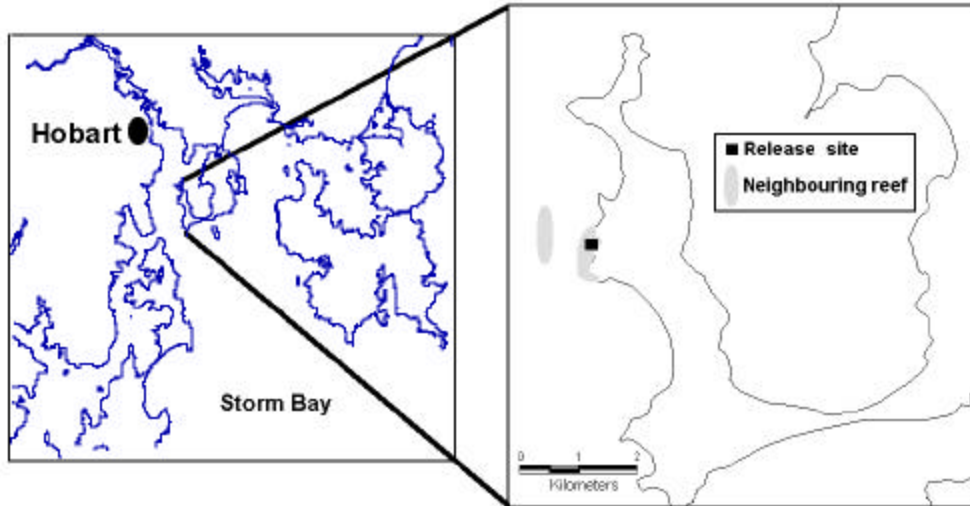

**Figure 6.** Location of the Jackson's square release site and areas of neighbouring reef surveyed .

## 7. Movement

### 7.1 Sonic tagging equipment and field methods for acoustic tracking

While studying movement patterns was not a primary objective of this research, information on likely scales of movement is vital in developing robust methods of estimating survival. Acoustic tracking was seen as the most viable method of obtaining reliable data on short-term movement. Radio tracking is not an option, as radio frequencies do not travel well in the high conductivity marine environment. Electromagnetic tracking has been used successfully with small lobsters (Jernakoff and Phillips, 1986), but its application requires specialist knowledge, and appropriate systems are not commercially available.

#### 7.1.1 Acoustic transmitter tags

In choosing appropriate acoustic tags, suitable compromise between several factors is required for individual applications.

- Size: given the small size of the lobsters in this study, the smallest possible tag is desirable. However, size is constrained by other factors.
- Frequency: higher acoustic frequencies can be generated by smaller membranes. However, acoustic interference from sources such as water moving over rocky reefs or waves breaking on the shore will be worse at high frequencies, and range is correspondingly shorter. An acoustic range of below 100kHz was considered desirable.

- Longevity: the longevity of a given type of battery is directly related to its size. Within the scope of this preliminary study, the 21 day life span of commonly available tags was considered adequate. Tags are attached externally and are lost at moult, so long term acoustic tracking is not an option.

Tags chosen for this study were Sonotronics IBT96-1 tags measuring 8mm x 18mm, weighing 1.5g with a working life of 21 days. Since lobsters are gregarious, and were to be released at the same location, it was considered likely that tagged animals would remain within acoustic range of each other. To allow individual identification of tagged lobsters, it was necessary to use tags emitting different frequencies. Frequencies of the tags (60kHz - 80kHz) were separated by 1kHz, so a receiver with a bandwidth of less than 2kHz was required to distinguish individual tags. Tags also emitted a unique pulse code which was useful as a secondary method of verifying tag identification.

### 7.1.2 Boat-mounted tracking apparatus

Sonotronics USR 5W scanning receiver was chosen due to its narrow (1kHz) bandwidth, scanning ability to simplify searches, and relatively low cost. This receiver provides an audible signal from the tag (via a 6mm jack socket), and a visual readout of tag pulse interval (used for conveying data by some telemetry tags). The receiver can be set to scan 10 frequencies, or frequency can be manually selected. The receiver was coupled with a directional hydrophone (Sonotronics DH-4) to maximise our ability to pinpoint the location of lobsters (Figure 7).

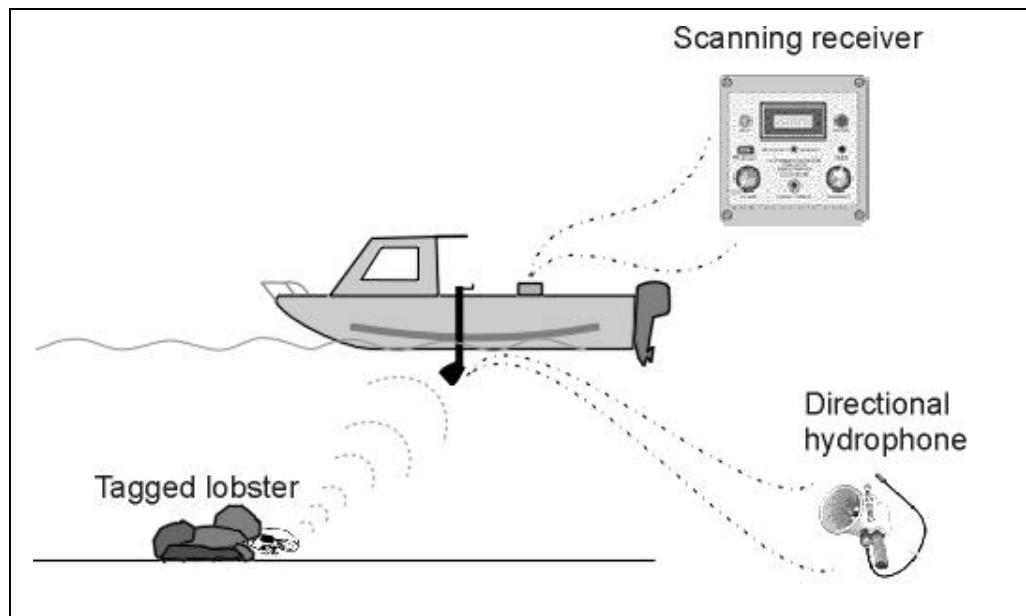

**Figure 7.** Schematic representation of boat-mounted acoustic tracking apparatus.

The hydrophone was mounted on a custom-built aluminium arm secured to the gunwale of the boat, allowing rotation and angular movement of the hydrophone head. A small set of powered speakers were connected to the receiver in preference to headphones, to enable both the boat operator and the hydrophone operator to hear signal strength and react accordingly.

Initial field trials showed tags were detectable at a range in excess of 500m in open water (tag placed on sand), and position could be determined to a 'circle of uncertainty' approximately 10m diameter. Detectable range was reduced significantly, to between 20 and 100m, when tags were placed on structured reef.

Ability to accurately fix the position of tags increases considerably with experience of the hydrophone operator and the boat operator. Once the initial signal was detected, the hydrophone operator continued to rotate the hydrophone head through an arc of approximately 180°, gradually narrowing the arc as the boat was driven towards the signal, and the signal strength increased. As signal strength approached maximum, the hydrophone was moved in the vertical plane, so as to be facing directly down towards the sea floor. At the point where the signal was strongest at this angle, the tag was deemed to be directly underneath the boat. On occasions, a single pass with the boat failed to identify the position of the tag with acceptable uncertainty. In such cases, the location of the strongest signal was noted, and the area approached again on a perpendicular trajectory, starting from a distance of 20 - 30m. This approach usually resulted in the tag positions being estimated to within an area where the tag signal could be received by the diver-held receiver.

### 7.1.3 Diver-held receiver

The diver-held receiver was used to locate the tagged lobster underwater after initial location by the boat held receiver. This allow us to observe habitat usage, den choice and to recapture lobsters at the completion of tracking trials. Market choice of submersible receivers is limited, and of three units assessed, the Vemco VUR-96 unit was most suitable (Figure 8). Frequency can be selected between 30 kHz and 80 kHz, with a bandwidth of 2.5kHz.

This bandwidth was slightly too wide as it allowed the simultaneous detection of two tags separated by 1 kHz (see section 7.1.1). This problem was overcome by using the unit in combination with the narrow band boat-mounted receiver, and also by recording the unique pulse codes emitted by the tags.

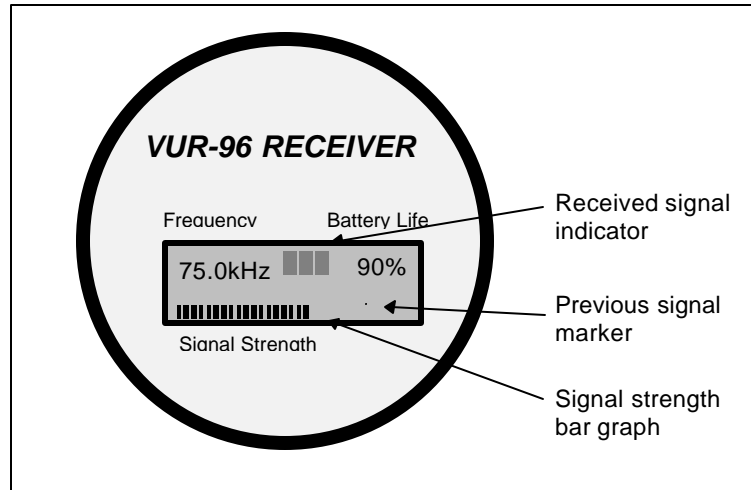

**Figure 8.** Front panel display of Vemco VUR-96 diver held receiver

#### 7.1.4 Acoustic tracking protocol by divers

Success rate of locating tagged lobsters was maximised by employing the following sequence:

1. Position of tag was determined as accurately as possible using boat-mounted tracking equipment, and a marker buoy deployed.
2. Diver entered the water with the hand-held receiver, and swam on the surface until a signal was received.
3. Diver descended facing towards the strongest signal.
4. After receiving a signal on the sea floor, the diver swam a short distance (2-5m), stopped, scanned with the receiver until the direction of strongest signal was identified, and swam towards signal, repeating until the tagged lobster was located.

As with the boat-mounted receiver, it was sometimes necessary to approach the area where the tag is thought to be from a number of angles. If a lobster was in a deep crevice facing away from the diver, it was possible to swim directly over the lobster and not detect a strong signal. Likewise, echoes off adjacent rocks could be misleading.

Ease of tracking lobsters with the diver-held unit was directly related to water conditions. Some difficulty was experienced when there was a large amount of suspended sediment, a distinct halocline, or when sea conditions were rough.

#### 7.1.5 Tank trials of acoustic tagging method

Tank trials were conducted to test methods of attaching acoustic tags so that they remained on the lobsters for a period of 21 days. We were also concerned that the tags, and the system for attachment, should not restrict the mobility of lobsters. To test the attachment method, 18

mock-tags were constructed. These were cast with epoxy and had a diameter equivalent to that of the acoustic tags (8mm). Lead shot was added to the castings to approximate the weight of the tags. Six replicates of 3 adhesive types were tested: Supa-Glue™; Need-It™; and 5-Minute Araldite™. The carapace of each lobster was thoroughly dried using paper towel and compressed air prior to attachment. Lobsters were held out of water for 5 minutes once tags were in place to allow adhesives to start hardening. After tagging, lobsters were held in a 4m<sup>3</sup> tank with brick hides for 21 days.

Five minute Araldite™ was the most suitable adhesive, with no tags being lost during the trial (Figure 9). Supa-glue™ initially appeared to be ideal, as curing time was less than for the other adhesives so that lobsters were held out of the water for shorter periods. However, its low viscosity combined with the opposing curved surfaces of the tag and the carapace resulted in a small contact surface area, and a weak bond. Supa-glue™ may be suitable for attachment of tags or markers that conform better to the shape of the carapace, or are flexible (eg. numbers written on waterproof paper).

From observation of tagged lobsters interacting with untagged lobsters, mobility did not appear to be impeded by the presence of tags, and tagged lobsters were as likely to be seen in the most sheltered hides as untagged lobsters.

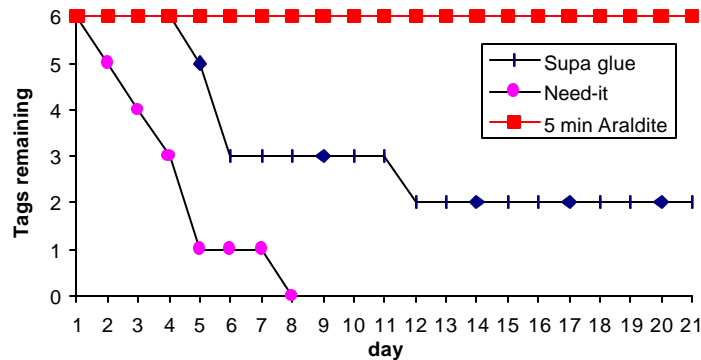

**Figure 9.** Retention of mock-up acoustic tags by juvenile lobsters with 3 attachment adhesives.

#### 7.1.6 Field trial of tagging and tracking methods

Given the lack of knowledge of scales of movement of juvenile lobsters, and the expense of the acoustic tags, it was considered unwise to attempt a full-scale release without first trialing tracking methods in the field. A single on-grown lobster was released and tracked daily for a period of 1 week. The release site (Shepherds Point - Figure 5) was chosen because of weather conditions forecast for the period available for this trial. Strong westerly winds made the Glenvar Point site unworkable. Shepherds point is sheltered in westerly conditions, and was known to include lobster habitat.

During the week of tracking, the lobster moved between dens within a radius of 5m, and was successfully relocated on each day and recaptured at the conclusion of the trial.

### 7.1.7 Study design and field methods for movement experiments

Movement information was collected during this project from two sources. The first was the acoustic tracking experiments which is the focus of section 7. Additional information on movement was also collected during the course of the larger scale release of antennal tagged juveniles and this is also presented here.

#### 7.1.7.1 *Acoustic tag experiments*

Following tag attachment experiments and initial field trials, three groups of acoustically tagged juvenile lobsters were released. Specific experimental aims for each are given below:

##### *Release 1. Glenvar Point:*

Nine tagged lobsters released, three from each the following treatment groups:

- on-grown lobsters
- wild-caught lobsters captured at the release site
- wild-caught lobsters captured away from the release site

The aim of this release was to assess the likely scales of movement away from the release point, and to determine the appropriate size of area to be searched by divers in a large-scale reseeded exercise. Two groups of control animals were included: lobsters captured on the release reef; and lobsters captured on neighbouring reef. The second group were included to assess whether lobsters captured at neighbouring reef sites exhibited any 'homing' behaviour.

Lobsters were tracked using boat-mounted and diver-held receivers. Once located by divers, notes on lobster habitat preference were made, and a brick with surface buoy attached was placed adjacent to the lobster den. Once all lobsters had been located, divers at the surface then used a tape measure and compass to obtain distance and bearing to buoys marking the previous position of each lobster.

##### *Release 2: Glenvar Point:*

Ten tagged lobsters released, five from each of the following treatment groups:

- on-grown lobsters;
- wild-caught control lobsters.

Acoustically tagged lobsters were released concurrently with the large scale release of antennal tagged lobsters to simulate a reseeded operation (see 7.1.7.2 below). Lobsters were tracked using the boat-mounted receiver only, and position marker buoys were deployed from the tracking vessel. Distances between marker buoys were measured as in Release 1.

### *Release 3: Bicheno*

Four on-grown lobsters were released at Bicheno as a preliminary trial of tracking and survival in a habitat unlike that of the Glenvar Point site. Lobsters were tracked using boat-mounted and diver-held receivers.

#### *7.1.7.2 Visible tag experiment*

The primary aim of the release of antennal tagged lobsters was to test techniques for measuring the relative survival of on-grown and wild juvenile lobsters. As knowledge of movement is integral to survival estimation, movement results are presented here.

The reef at Glenvar Point was divided into a grid for referencing the position of re-sighted lobsters. The grid measured 32m by 32m, and was divided into 64 grid squares (4m by 4m). Further details of the site set-up are presented in section 9.2. Antennal tagged lobsters (see section 5.4) were released onto the site on 2 consecutive days (Table 1). Lobsters were released in daylight, from a single bag placed in the centre of the reference grid. No attempt was made to assist lobsters in finding suitable habitat or in dispersing.

**Table 1. Numbers of juvenile rock lobsters from control and on-grown groups released with antennal tags.**

Resighting information is the number of individual animals resighted and the number of resighting occasions (as one individual can be resighted on several occasions).

	<b>On-grown</b>	<b>Control</b>	<b>Total</b>
Released Day 1	364	130	494
Released Day 2	63	23	86
<b>Total released</b>	<b>427</b>	<b>153</b>	<b>580</b>
Resighted (individuals)	172	109	281
Resighting occasions	356	268	624

The release grid and adjacent reef areas were surveyed by divers on 9 occasions over a period of 1 month, initially every second day, becoming less frequent. Position of antennal tagged lobsters was recorded by grid reference within the release grid, or by distance from the release site for adjacent reef areas.

## **7.2 Results of movement research**

### *7.2.1 Practical observations on the technique of acoustic tracking*

The ability to relocate acoustically tagged lobsters on rocky reef using acoustic tracking was impressive. In release 1, all lobsters were tracked successfully over a period of 14 days, and recovered at the completion of the trial. The ability to resight lobsters using the diver-held receiver enabled accurate observations to be made on behaviour and habitat choice of treatment groups. Accuracy of locating lobster position with the boat-mounted receiver increased with operator experience, to a point where surface-deployed marker buoys were

often placed within a 1-2 m radius of the lobster position. Accuracy continued to be dependant on bottom topography, with features such as rock channels and ledges that may reflect or channel acoustic signals reducing accuracy.

Individually tracking each animal is labour-intensive and costly, and is limited by the following factors:

- Time taken to locate lobsters. On average, locating a lobster took 15 to 30 minutes from the time of first receiving a signal.
- Diver safety. University of Tasmania dive code stipulates that a diver can only perform 3 ascents in a day.
- Available frequencies. Tags are only manufactured within a limited range of frequencies. Tags must be on separate frequencies to individually identify lobsters.
- Cost - Current cost of acoustic tags is A\$385 each

Nine or 10 lobsters, as tracked in these trials, can be tracked by a team of 3 people in 1 day. Any more would become difficult, particularly in poor conditions. This practical limit to numbers of replicate observations may lead to a lack of power in detecting any group effects within an experiment (see section 7.2.3.1).

Radio acoustic positioning and telemetry (RAPT) has been suggested as an alternative system to locating tags by boat and divers. The RAPT system uses acoustic tags, with a series of 3 or more permanently moored receiver buoys set around the study site. The time at which acoustic signals are detected at the receiver buoy can be used to triangulate the position of the tag. Data from these buoys is transmitted to a computer base station. In this way 'real-time' tracking can be achieved. This is highly preferable to the single daily position reports available from manual acoustic tracking. This system has been used with good results for tracking fish and cephalopods (Sauer *et al.* 1997, O'dor *et al.* 1998). However, there are features of these systems that limit their use for tracking lobsters. While labor costs are reduced by the automation of position recording, set up costs are in the order of 10 times that for manual tracking (based on VEMCO VRAP system). If lobsters move outside the area covered by moored receivers, tags must be tracked manually, negating the advantages of the system.

Van der Meeren (1997) used a RAPT system to track 4 native and transplanted European lobsters (*Homarus gamarus*) in an open sea lagoon. Despite setting the system to record lobster positions every 50 seconds, there were often several days at a time where no valid fix was taken for a particular lobster. Position fixes were found to be unreliable, due to reflection of transmitter signals of rock surfaces, and accordingly were often verified by manual tracking. The author concludes that this tracking system is not suited to use with shelter-seeking animals in high relief environments.

## 7.2.2 Daily movement patterns

### 7.2.2.1 Sonic release 1

All lobsters from release 1 were tracked throughout the 14 days of the trial, however, not all lobsters were located on each day. One control lobster (relocated) was detected by the boat mounted receiver but not cited by the divers on days 3 or 4. One on-grown lobster was not located for 2 days after release, but was relocated 140m due west of the release site on day 3 (Figure 10). This lobster had moved over approximately 100m of unstructured sand habitat, and settled in an area of reef cohabited by wild lobsters. One lobster from each treatment moved in excess of 50m away from the release site during the experiment.

Wild caught lobsters relocated from adjacent reef showed no homing tendencies; the single relocated wild lobster that moved in excess of 50m did so in a direction away from its home reef. Three lobsters (2 control (relocated) and 1 on-grown) took up residency in a den and were consistently sighted in the same location after day 2 to 5 of the trial.

Data from the 3 treatments were pooled to calculate the optimal search area for re-sighting visually tagged lobsters released in the reseeded trial (Figure 11). By superimposing a grid of varying size onto the plot of lobster positions, a search area that would give a good coverage of predicted movement without excess effort could be determined. The Jackson square technique we intended to evaluate for survival estimation (see section 9.1.1) does not require all animals to be resighted, however, precision is increased where most animals do not move beyond the survey site. This analysis indicated that the most efficient search area is a 32x32 m square, which was subsequently adopted for the large scale release experiment.

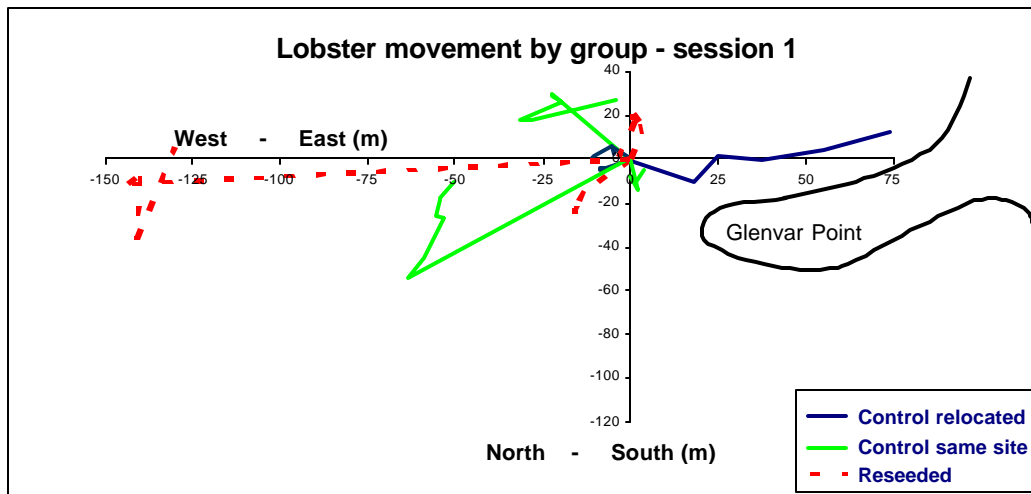

**Figure 10.** Daily movement tracks for nine lobsters from 3 treatment groups in release 1.

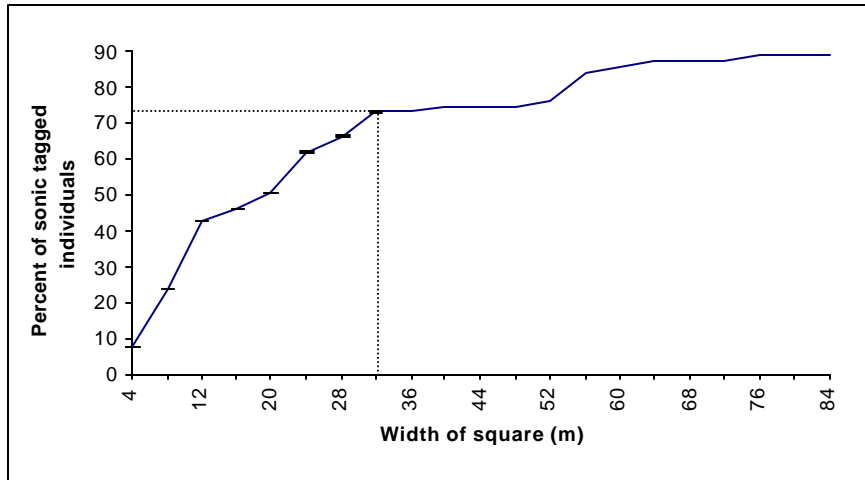
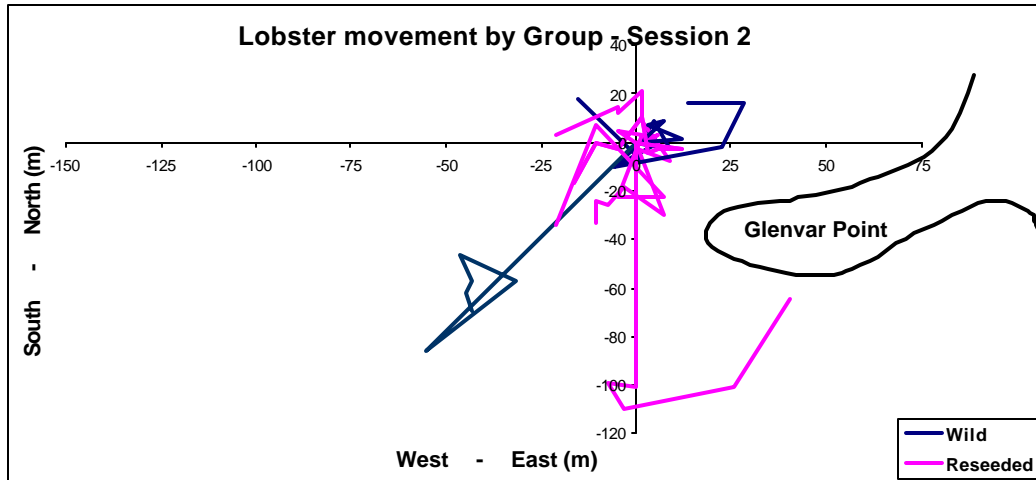

**Figure 11.** Estimation of appropriate experimental square size for isolation of survival and movement with the Jackson Square Technique. Data was pooled for all daily locations of sonic tagged lobsters of all groups: on-grown; control transplanted; control from same site. The X-axis refers to the dimension of the square required to contain the number of resighting observations listed on the Y-axis. For example, the dashed line indicates that a square of 32x32m would enable divers to encounter 73% of tagged lobsters (assuming all tagged lobsters within the square are seen).

A hand spear was used to collect a small number of large predatory fish from areas adjacent to the release reef. A single lobster of 42mm carapace length was removed from the stomach of a large blue-throated wrasse (*Pseudolabrus tetricus*). No antennal tag was found attached to the carapace or in the stomach.

#### 7.2.2.2 Sonic release 2

Five acoustically tagged lobsters from each of 2 treatments (wild and on-grown) were released concurrently with 580 antennal tagged lobsters (see section 9.2). Acoustic tags were tracked for 14 days using the boat-mounted receiver only. Movement patterns were similar to those seen in release 1, with the majority of movement occurring within the 32m<sup>2</sup> grid. One lobster from each treatment made a significant excursion beyond this area.



**Figure 12.** Daily movement tracks for nine lobsters from 2 treatment groups in release 2.

### 7.2.2.3 Sonic release 3

Bicheno differed from the release site at Glenvar Point, Southern Tasmania by the presence of more large fish and also in the greater structural relief to the reef. The reef at this site is granite and we found acoustic tracking more difficult due to echo and loss of signal.

Of the 4 on-grown lobsters released at Bicheno, 3 were detected with the boat-mounted receiver on the first day after release. The first was located alone, within a hide 30m east of the release site. This lobster was relocated over the following 2 days and had not moved. The second was repeatedly heard at a distance but was not located precisely. The location of this tag appeared to change rapidly leading to speculation that it may have been within the stomach of a moving predator such as a large fish.

The third lobster was located in a crevice partially eaten by a large seastar (*Asterostole scabra*). It is not possible to definitively say whether this lobster was killed by the seastar, however there were no signs of trauma to the lobster carapace, and the lobster appeared healthy prior to release. Other large seastars (*A. Scaber* and *Coscinasterias muricata*) in the area were found to be eating velvet crabs (*Nectocarcinus tuberculosis*) so they appear to be able to trap crustaceans in some habitats.

## 7.2.3 The effect of group on movement patterns

### 7.2.3.1 Sonic tracking data

The effect of group (on-grown vs control) on movement was analysed for each sonic tagging trial separately and with data pooled. Data were first arc-sine transformed to correct for lack of normality. Where animals did not appear to have moved between samples, their movement was recorded as 1 meter to overcome problems with zeros in the data set. Analysis was by MANOVA with movement between each tracking survey treated as a separate response variable. Treatment effects were: i) the release group (before the large scale release /

simultaneously with the large scale release) and ii) the source of the released animals (on-grown /wild control). Data failed sphericity testing by the Mauchly criterion so the adjusted Greenhouse-Geisser test was used to test significance.

No significant effect was detected for either the animals source (on-grown vs control) or release group (before or simultaneously with the large scale release;  $P > 0.3$ ). While this indicates that both on-grown and control juveniles moved similar amounts between samples, the data was drawn from comparatively few animals (8 on-grown and 10 control) and was highly variable. Some animals moved less than 30 m throughout the trial while others moved almost 300 m. This suggests that the sonic tracking data may have limited value in assessing group effects.

### 7.2.3.2 Antennal tagging results

Almost 3 times as many on-grown lobsters were released as control lobsters (Table 1). However, by the time of the first survey within the 32x32 m grid, the resighting ratio was about 1.5:1, and remained at about 1:1 inside this area from the second survey until the completion of field work (Figure 13). This indicates that there was a group effect on the resighting of juveniles lobsters - that is, the ongrown animals were less likely to be resighted.

This group effect could be due to greater mortality, greater movement out of the Jackson square area, or lower visibility of on-grown lobsters. Questions of mortality and visibility are further investigated through multi-strata modelling (section 8).

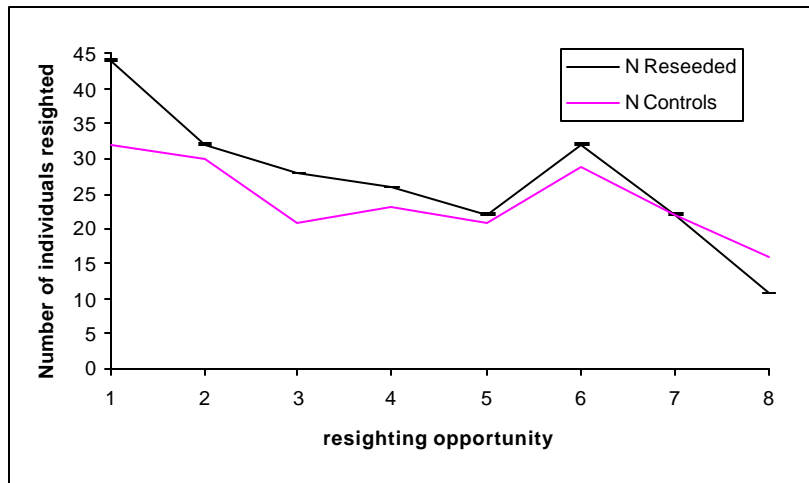
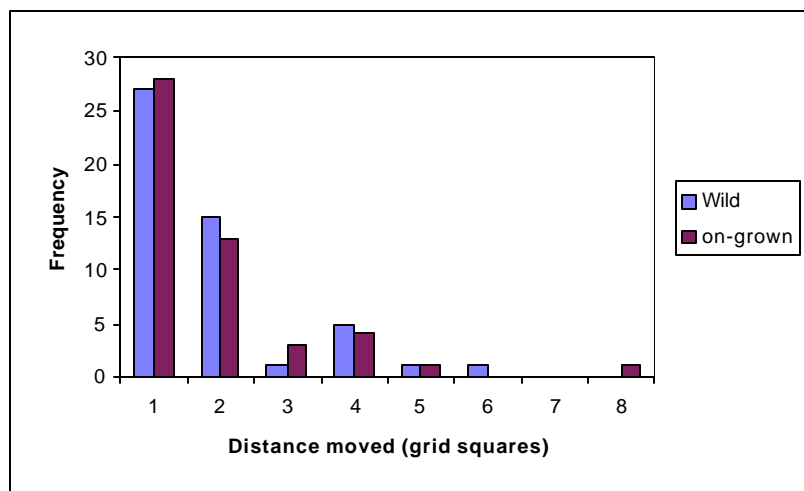

**Figure 13.** Change in the number of antennal tagged lobsters resighted as a function of group and resighting opportunity. Note that there was a trend of decline in number of animals resighted from both groups through time, indicating a gradual trend of either movement away from the site, mortality, or a reduction in resighting probability (see section 9.6). On the first resighting opportunity, the proportion of on-grown animals (58%) was considerably less than at release (73%). The maintenance of this ratio would have required the resighting of around 86 on-grown individuals at time 1, rather than the 44 observed. The proportion of on-grown animals continued to decline sharply until survey 2 and both groups were similar thereafter.

We attempted to assess if movement of tagged lobsters within the Jackson square grid indicated any group effect on movement patterns - that is, does greater movement by the ongrown animals account for the apparent decline in their abundance seen in Figure 13 ? There appeared to be little difference in rates of movement between the treatment groups inside the Jackson Square (Figure 14). Resighting data from inside the Jackson square also indicated that movement was generally small with most lobsters sighted on consecutive days moving only a short distance to an adjacent grid square.

However, transects and searches beyond the Jackson square grid suggested otherwise. During the final resighting survey by divers, transect searches were performed to a distance of 800m from the release site. As distance from the release site increased, the proportion of on-grown lobsters resighted by divers increased (Figure 15). Interpolation of this plot suggests that beyond a distance of 180m from the release site, the proportion of on-grown lobsters sighted was higher than initially released. This demonstrates that movement patterns by the two treatment groups are distinctly different; the distance moved by on-grown lobsters was considerably greater than the distance moved by controls.

This effect was not detected in the Jackson square. The most probable explanation is that between release and the first resighting opportunity, large numbers of on-grown lobsters moved beyond the Jackson square area and nearby reef. The fact that this movement pattern was not detected from data collected within the Jackson square suggests that our grid was too small and that the Jackson square technique will fail to correct for the bias of emigration.



**Figure 14.** Frequency distribution of distances moved (in grid squares) indicated similar distances moved by on-grown and wild lobsters sighted on consecutive days. Few lobsters appear to have moved a distance greater than 2 grid squares.

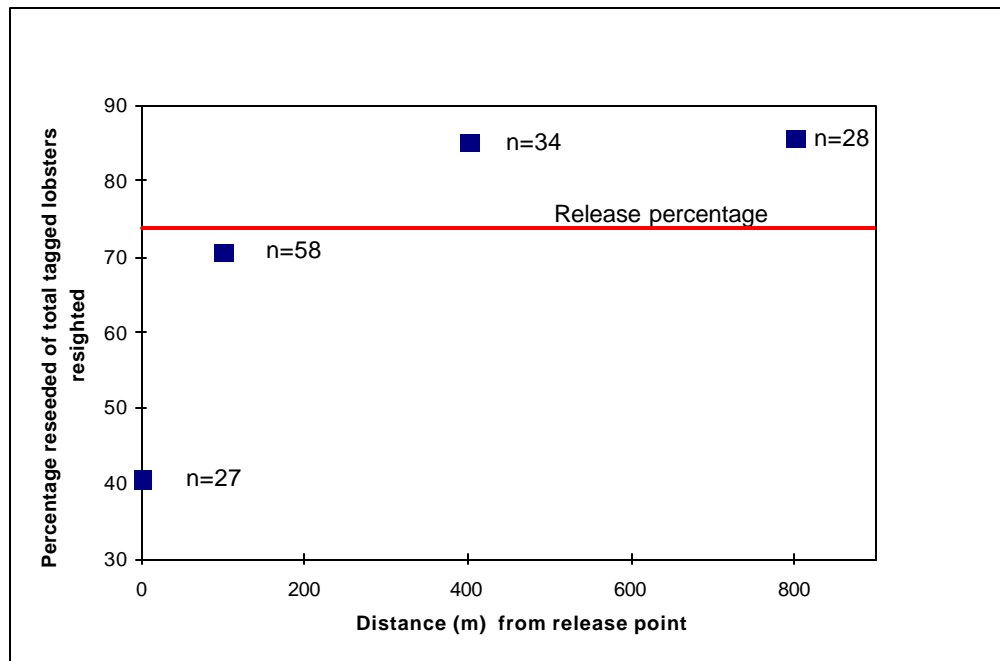

**Figure 15.** Comparison of movement of control and on-grown rock lobsters. Counts of on-grown rock lobsters from transects were conducted on the last resighting opportunity (sample 9) at a range of distances from the release site. The proportion of on-grown animals is lowest near the release site but increases with distance. This demonstrates that on-grown animals tended to move further from the release site than controls.

#### 7.2.4 Density dependent effects on movement

Results shown in section 7.2.3.2 indicated that movement of the on-grown juveniles was larger than was predicted by the initial sonic tracking study. This implied that the Jackson square layout was too small to provide meaningful estimates of emigration - as discussed above.

We would expect intuitively that this change in movement patterns may be a density dependent effect. Lobsters may exhibit different movement patterns due to the increased density on the reef following the large scale release; shelter and food would be less available so animals may move further to locate these.

A density dependent increase in movement was supported by comparison of movement patterns of acoustic tagged lobsters released before and concurrently with the large scale release. Movements of the second group tended to be higher throughout the 17 day duration of the trial (Figure 16), with the exception of the first 4 days, where variation was very high.

Similarly, a difference in resighting rate was observed between antennal tagged lobsters released in different densities on 2 consecutive days (494 on day 1; 86 on day 2). A

consistently higher percentage of lobsters from the second release were resighted within the Jackson square grid (Figure 17). While not conclusive, a plausible explanation is greater movement away from the site by lobsters reseeded at a higher density.

While there appears to be evidence of a density dependent increase in movement of both groups, this does not explain the greater movement of ongrown juveniles relative to wild controls (Figure 15). We expected the opposite result as ongrown animals had been held in tanks at high density so we expected them to be more tolerant of higher density. We remain uncertain on the reason for the greater movement of ongrown animals but stress that it is an important effect to consider when modelling survival.

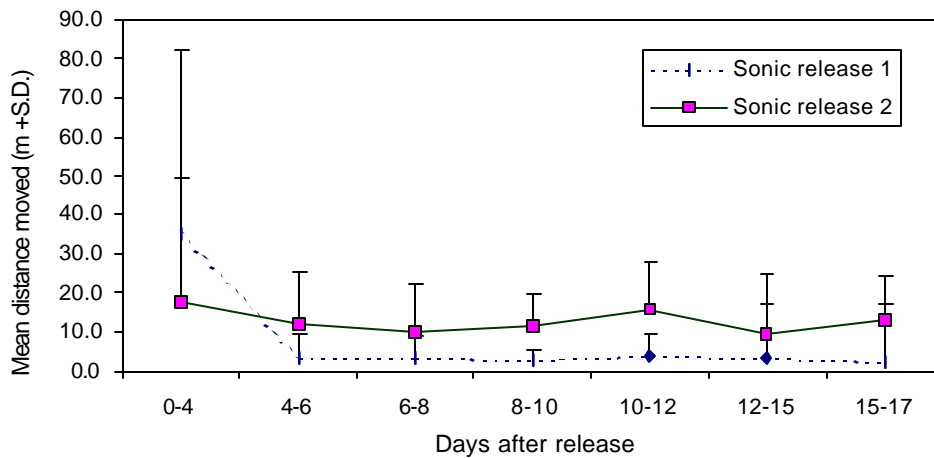

**Figure 16.** Mean distance moved by sonic tagged lobsters released either in a single group (release group 1), or released simultaneously with the 580 juveniles released as part of the larger scale reseeded experiment (release group 2). Each release group consisted of 9 animals. Means are geometric means plus standard deviation. While this presentation of variation is not entirely appropriate as raw movement data are not normal, the plot is only intended to indicate similarity of general patterns with antennal tag resighting data - the effect of release group was not significant.



**Figure 17.** Effect of release group on resighting probability within release site only (ie excluding resights from neighbouring reef). Release-Group 2 was released a day after Release-Group 1 and the first resighting opportunity occurred the following day. The two groups shown here combine on-grown and control animals which is valid as the ratios of these were consistent between release groups (27% control animals in 1<sup>st</sup> release vs 26% control animals in 2<sup>nd</sup> release). The trend of higher resighting of animals from the second release implies reduced movement away from the site, given that apparent survival was close to 1 (see section 9.6).

### 7.3 Discussion in relation to estimating survival in juvenile lobster reseeded

Movement of sonic-tagged lobsters failed to accurately predict the scale of movement, or differences between control and on-grown lobsters seen in the large-scale reseeded experiment. Evidence presented above suggests the change in distance moved may be attributable to density dependant effects. Inability to detect group differences from acoustic tracking data are likely to be a consequence of low numbers of tagged lobsters.

The Jackson Square grid (based on results from sonic tracking) proved too small to provide valid emigration estimates in the large-scale release. A square grid large enough to cover movement seen in antennal-tagged lobsters may be too large to be practically searched by divers, however an adaptation of this technique to coastal strip-reef, involving small squares placed end-to-end, may be workable (see section 9.1.1).

Based on the observed movement patterns, we concluded that multi-strata Cormack-Jolly-Seber models are more useful than the Jackson square method for this data set. Such models are flexible enough to incorporate group and movement effects, and would be suited for serial release and resighting of tagged animals in future experiments. For future trials, serial release of experimental animals presents considerable advantages. In the current study, resighting rate was higher for the second, smaller release, probably due to density dependent movement. The adaptability of multi-strata modelling to serial release, and likely increased resighting rates will result in more robust parameter estimates

Apparent density dependent effects also have implications for reseeded commercially harvested puerulus. Intuitively, it would be expected that newly reseeded lobsters would be most susceptible to predation when moving, presumably in search of shelter or food. Consequently, lower density reseeded would be expected to reduce movement and may improve survival rates.

In future reseeded trials, finer definition sampling will be required in the period immediately following release. There has clearly been considerable large-scale movement in this period that was not picked up by the Jackson square sampling. As a period of high movement, it is likely this is also the period of highest mortality.

## 8. Feeding by On-grown Juveniles

Although the feeding behaviour of juvenile rock lobsters reseeded after being ongrown in captivity was beyond the scope of the current project, some information was collected during the process of acoustic tracking. The ability of juvenile lobsters to find, capture and consume food is clearly important in the context of measuring survival, especially as the reseeded experiment was conducted over only a short period in this instance.

Direct observations of reseeded juvenile lobsters indicated they were exhibiting typical foraging behaviour. Animals with acoustic tags released in sonic release number 1 (section 7.1.7.1) were tracked every 3 hours by divers for the first 48 hours. Reseeded juveniles exhibited normal behaviour of moving around the reef at night and sheltering in holes, often communally, during the day. While this indicates normal movement behaviour, it does not demonstrate that reseeded lobsters were feeding while moving around the reef.

To test if reseeded lobsters were feeding, we recaptured all acoustic tagged animals from release 1 on the morning of day 14 of the study, plus an additional 9 untagged wild lobsters. Stomachs were removed, and a gut fullness index recorded on the basis of ratio of weight of stomach including contents to stomach without contents (Figure 18). While gut fullness indices were variable, those of on-grown lobsters were within the range of those of wild lobsters, and the presence of acoustic tags did not appear to inhibit feeding. A single local control lobster (acoustic tagged wild juvenile from the same reef) had an empty stomach, and was in pre-moult condition.

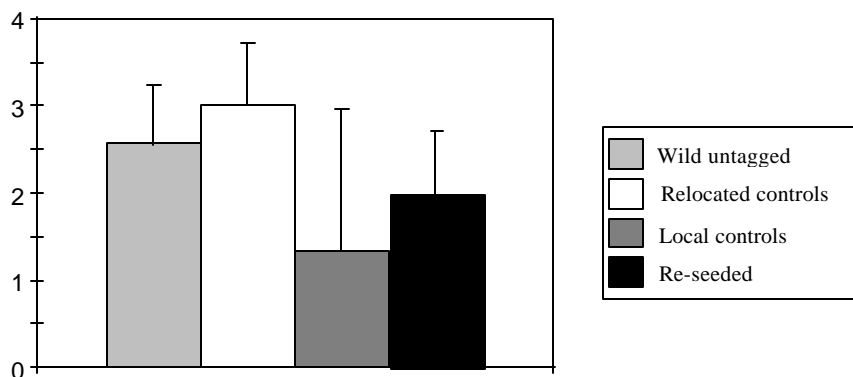

**Figure 18.** Gut fullness indices of recaptured acoustic tagged lobsters and wild lobsters caught concurrently.

## 9. Reseeding experiment

This section describes the large scale release experiment with antennal tagged ongrown and wild control juveniles.

### 9.1 Analytical methods for survival estimation

Although movement of juvenile rock lobsters of either control or on-grown groups was not of primary interest for this study, we anticipated that it would be critical in the estimation of survival. Two analytical approaches are discussed here, the first is the Jackson Square technique which incorporates a fixed ratio in likelihood of emigration between a large site and a smaller site within it. The second approach was to include movement parameters (between the main site of release and surrounding reef) in a multi-strata mark-recapture model that was used to derive survival estimates. When reading the discussion of the two approaches it is important to remember the primary aim of the survival estimation process was to accurately evaluate if there was an effect of group (ie control or on-grown animals), providing accurate survival estimates was secondary.

#### 9.1.1 The Jackson Square technique

Survival estimates obtained by tag recapture techniques, such as the widely used Cormack-Jolly-Seber (CJS) technique (Lebreton et al., 1992), can be biased by emigration away from the study site. Estimated survival is effectively a product of the true survival and the probability of remaining within the search location. As a result, survival estimates by the CJS technique are merely the lower limits of the true survival rates. This is especially problematic where group effects are confounded by varying emigration rates. Emigration has been problematic in the use of mark-recapture techniques for estimation of population size, although fortunately, estimates of survival are more robust to partial failure of assumptions (Lebreton et al., 1992).

This problem of emigration has been recognised for decades and a simple solution was proposed by Jackson (1939) which involved the measurement of movement between adjoining cells or blocks within a study site. Manly (1985) reviewed this method using simulated data and concluded that it yielded relatively unbiased estimates of survival, even with high levels of emigration.

The Jackson Square technique relies on the assumption that emigration rates from a large square (site) will be less than from a smaller square (site), and that this difference will be proportional to the size and geometry of the two areas (Figure 19).

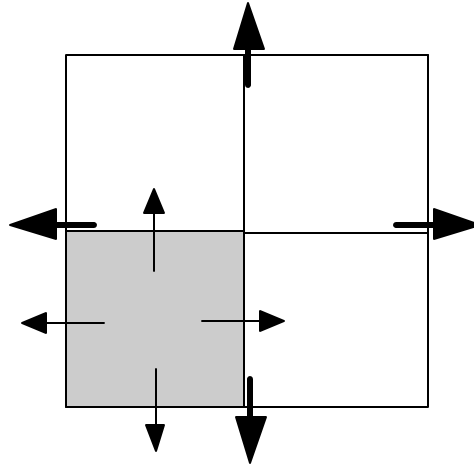

**Figure 19.** Layout of a Jackson Square site for mark-recapture studies. As the smaller square shares 2 of 4 sides with the larger square, half the emigrating animals will be recaptured within the larger square. Note that the scale of movement between samples should be around the size of the squares or less. Information on directional movement (non-random) is obtained by comparison of estimates of survival for each of the small squares, although the ability of the method to correct for non-random movement is limited.

Jackson's (1939) method can remove the bias of emigration in the calculation of survival and also provides an estimate of emigration which can be of interest. Manly (1985) calculated migration-biased estimates of survival for the small squares and also the larger square by the CJS method which incorporates parameters for recapture probability as a function of time (ie. a separate survival and recapture parameter for each sample period in the "full" or most parameterised model). The details of these models are discussed later as a variant of the CJS (multistrata mark-recapture) was used to estimate survival of on-grown and control rock lobster juveniles. The important point here is that tag recapture information can provide an estimate of survival from each square, from each time interval, that is biased by emigration. As with all models, the CJS method relies on numerous assumptions that are discussed later. These details will also affect survival estimation by the Jackson square technique.

Using the notation of:

$f_s$  = emigration biased survival estimate per sample interval for small-square;

$f_l$  = emigration biased survival estimate per sample interval for large-square;

$\hat{d}$  = the true survival probability ; and

$\hat{e}$  = the probability of emigrating from the small square per sample interval.

The emigration biased estimate of survival for the small square is a function of true survival and emigration:

$$f_s = \hat{d}(1 - \hat{e})$$

## Equation 1

and the emigration rate for the large square will be half of that for the small square if all directions of movement are equally likely,

$$f_l = \hat{d} \left( 1 - \frac{\hat{e}}{2} \right)$$

## Equation 2

Equations (1) and (2) can be solved as:

$$\hat{d} = 2f_l - f_s$$

## Equation 3

to obtain true survival, and

$$\hat{e} = \frac{2(f_l - f_s)}{(2f_l - f_s)}$$

## Equation 4

to provide an estimate of emigration.

Manly (1985) noted that sampling errors can result in higher estimates of  $f$  within the small square than in the large square, in which case  $\hat{d}$  is estimated by  $f_l$ .

This process can be repeated for each of the 4 small squares within the site. Assuming goodness of fit tests are met for the CJS estimates and sample sizes are adequate, similar results from each analysis provides confidence in estimates while disparity suggests large error or a violation of the assumptions of Jackson square. An important violation in the context of the current study is the assumption of emigration from the large square being half as likely as from the small square. This assumption is violated when movement is directional (eg along prevailing current) or when the habitat and thus emigration is heterogenous.

#### 9.1.2 Multi-strata mark-recapture estimates of survival for on-grown and control juveniles.

Multi-strata models are survival models which include the effect of transition between different “strata”, where strata can be different biological states (eg ovigerous / non-ovigerous) or spatial areas. In this study we were interested in their application to recaptures from different areas. Preliminary analyses indicated that the number of parameters involved in survival modelling would result in unworkable models when the number of strata were high (with 8 resighting surveys), so we restricted the strata to two. These strata were: (1) the release site and surrounding 5 m strip, and (2) the neighbouring reef which was searched by divers in all directions until counts of tagged animals on 50 m transects dropped to zero.

The multi-strata mark-recapture models used here are an extension of the Cormack-Jolly-Seber model (CJS) (Cormack 1964, Jolly 1965, Seber 1965) and do not directly overcome the bias of emigration (remember that the Jackson square technique uses CJS estimates of “apparent survival” to derive “true survival”). Nonetheless, multi-strata models are of value for assessing the reseedling of rock lobsters as they allow survival to be partitioned into spatial strata, and also provide information on the transition of animals between these strata (ie movement).

Group parameters can be included so the relative movement and survival of control and on-grown juvenile rock lobsters can be examined. While this method does not overcome the bias of emigration on survival estimates, it does allow examination of the likely extent of emigration, and more importantly, if it is likely to affect either group more than the other (remembering that precision in group comparisons, rather than accuracy of survival estimates are paramount in this instance). Brownie *et al.* (1993) advocated the use of multi-strata models as the presence of movement parameters represent an attempt to introduce biological realism into survival models.

An attraction of multi-strata models for the current study was that they provided information on relative movement between the groups, without the need for a geometrically regular study site. Southern rock lobster juveniles inhabit rocky reef and although the release site was a relatively uniform boulder reef, the neighbouring areas were diverse with drop-offs, caves, and barren patches of sand. Because there was no need for geometrically defined search areas with multi-strata techniques, diver searches could be more extensive and the proportion of recaptures greater. So although the survival estimates remained biased by emigration, the magnitude of emigration from the search area was reduced.

The model structure used here was developed by Brownie *et al.* (1993) and Hestbeck *et al.* (1991) and was originally adapted for SURVIV by J.E. Hines. It was later incorporated into MARK by Garry White (Cooch and White, 1999) which was the program used for the analysis of data from this study.

The basic CJS model assumes that the proportion of tagged animals recaptured is a function of survival rate and the probability of tagged animals being resighted (Figure 20). The parameter estimation procedure provides estimates of survival by separating or identifying resighting parameters at each encounter opportunity. The theory of identification of parameters in the multi-strata model is explained below and draws on publications by Lebreton *et al.* (1992), Brownie *et al.* (1993) and Cooch and White (1999).

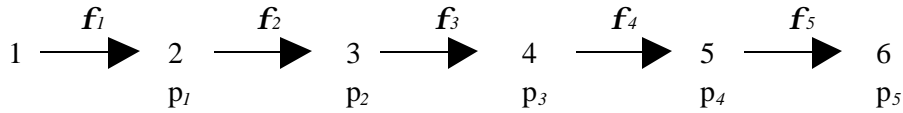

**Figure 20.** This scheme illustrates a tagging study with a single “batch” release at occasion 1 as was conducted with reseeded rock lobsters. Tagged animals seen at occasion 2, the first resighting opportunity, will be function of both survival rate over interval 1 ( $f_1$ ) and resighting rate at occasion 2 ( $p_1$ ).

Survival and resighting rates are identifiable as animals that have survived, but are not resighted, remain available for resighting on subsequent occasions. Thus the recapture histories of an animal that was:

released occasion 1 — not seen on occasion 2 — resighted occasion 3

provides a means of estimating the resighting parameter. As only two parameters are estimated for each occasion, survival can be identified. Note that the CJS technique requires at least two resighting opportunities after release.

The CJS model is extended to include movement between strata by expanding the survival parameter to:

$f_i^{rs}$  = the probability of an animal alive in strata  $r$  in time  $i$  is alive and in strata  $s$  at time  $i+1$ . This is illustrated in Figure 21.

Additional resighting parameters are required for each strata so that:

$r_i^s$  = the probability that a marked animal alive in state  $s$  at time  $i$  is resighted at time  $i+1$ .

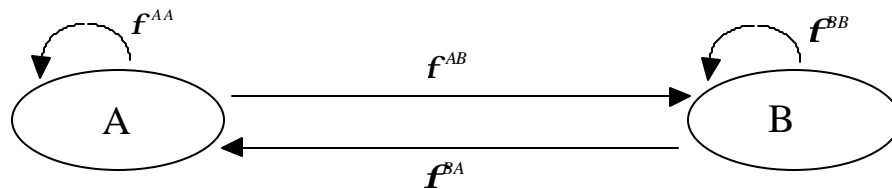

**Figure 21.** Schematic representation of survival probabilities between two strata as used in the rock lobster reseeded experiment. Strata A represents the release site and strata B represents the neighbouring reef.

While the estimation of a parameter that combines movement and survival as illustrated in Figure 21 is useful, for the study of rock lobster reseeded we were also interested in separating these two effects. That is, we aimed to obtain separate estimates of movement and survival. The multi-strata model available through program MARK achieves this by assuming

“Markovian survival”. This essentially assumes that animals survive and then move to a different strata, that is, survival is only estimated for the strata at occasion  $i$ , not at occasion  $i+1$ . While we would expect this assumption to be violated in many tagging studies, it would seem less problematic in the release of rock lobsters where the two strata are only separated by 10's of meters and would be expected to have the same predator suites. The ability to obtain survival estimates from both strata also provides information on the importance of this assumption - where strata has no effect on survival we would expect the assumption of Markovian transition to be acceptable. The assumption of Markovian transition between strata results in:

$$f_i^{rs} = S_i^r \Psi_i^{rs}$$

where  $S_i^r$  is the survival over interval  $i$  assuming the animal remains in stratum  $r$ , and  $\Psi_i^{rs}$  is the conditional probability that an animal in stratum  $r$  at time  $i$  is in stratum  $s$  at time  $i+1$ .

The survival and movement parameters are then separately identifiable because of the constraint that:

$$\sum \Psi_i^{rs} = 1$$

### 9.1.3 Summary of practical differences and assumptions in Jackson Square and Multi-strata techniques.

Survival estimates by both the Jackson square and the multi-strata techniques are influenced by six variables:

- 1) the population size;
- 2) the number and times of samples;
- 3) the probabilities of capture or resighting in the samples;
- 4) the amount of movement;
- 5) the true survival probability;
- 6) recruitment to the population;

A 7<sup>th</sup> variable is applicable to only the Jackson Square technique which is the method used for calculating estimates of  $\hat{\Psi}_l$  and  $\hat{\Psi}_s$  (Manly, 1985). This is because the emigration biased survival estimates for the small and large squares can be obtained by any one of several techniques, although the Cormack-Jolly-Seber (CJS) is most common.

Manly (1985) notes that the Jackson square technique may be limited by the pattern of movement of animals. There are implicit assumptions that:

- 1) emigration is not in any particular direction<sup>1</sup>;
- 2) **movement is generally not so large that animals will move from one small square into another and then out of the site entirely between two samples.**

These two assumptions were the subject of preliminary field work in the current study involving:

- 1) the identification of a site where reef provided suitable habitat for juveniles and where the structure was relatively homogenous over the scale of daily movements of juveniles - to reduce the risk of a trend in direction of movement (Section 6); and
- 2) estimation of the size of daily movement by control and on-grown juveniles so that the size of the grid would be appropriate (Section 7).

These two areas of research were followed by the establishment of a Jackson Square grid and an experimental release of reseeded juveniles.

The overriding aim of the project was to evaluate methods for estimating the survival of on-grown animals relative to controls, rather than providing information of the success or otherwise of the reseeded operation. For this reason, the Jackson Square grid was constructed with multiple squares (8x8, rather than 2x2) to allow analysis on different scales. This was to provide additional information on the second of the implicit assumptions on emigration - is the scale of movements so large that animals tend to move from one small square to the next and finally outside the large square between samples ?

Clearly larger squares provide increased search area and presumably increased precision, but this comes at the expense of increased diver time. The “best” size grid then would be one that balanced the conflicting goals of minimising dive time while still providing precise survival estimates. Results from the Jackson square were thus intended to complement estimates of movement made by sonic tracking of juveniles prior to the reseeded trial.

Both multi-strata models and the standard CJS model used for estimating survival in the Jackson square technique contain several assumptions. These are:

---

<sup>1</sup> While Manly (1985) was correct to note this assumption in the sense of a typical grid layout of the Jackson square, it is possible to adjust the ratio of movement between small and large squares where this is unequal but known, or assumed (ie. the value of  $\frac{1}{4}$  probability of emigrating in Equation 2). For instance, in a river the survival of fish in a large square formed by two small squares sharing a single border and

stretching from bank to bank to bank, would be calculated as:  $\hat{\Psi}_i = \hat{f} \left( 1 - \frac{\hat{e}}{2} \right)$ .

Movement is unlikely to occur in all direction because fish will only move up and down river, not on and off the banks. The important point in this extreme example is that movement is not equal in all directions, yet we are in a position to estimate values for the emigration on all sides of the square (by assuming zero emigration on 2 of the 4 sides of the small squares). In respect to rock lobsters, it may be possible to apply the Jackson square technique to thin coastal reef that runs down into sand and up onto shore. Rather than a grid layout, a series of squares end to end along the reef could be used and the assumption of zero movement across the sand or onto shore applied. Limited movement may occur over sand, but the estimate for survival will be less biased by emigration.

- 1) every animal in the population (of each group) has the same recapture probability for each resighting occasion  $r_i$ , given that it is alive and in the survey area;
- 2) every marked animal of each group has the same probability of surviving  $f_i$  from the  $i^{\text{th}}$  to the  $(i+1)^{\text{th}}$  sample;
- 3) every animal resighted in a survey has the same probability of being returned alive  $n_i$ ;
- 4) marked animals do not lose their marks and all marks are reported on recovery; and
- 5) sampling occasions are instantaneous relative to the period between samples, and releases are immediate; (Seber, 1982).

Assumptions (1) and (2) were tested formally by Goodness of Fit (GOF) analyses and are discussed in more detail in Section 9.4.1. Assumption (3) relates to accidental death of animals through the sampling process ( $1-n_i$  = accidental death). This assumption can be a problem in tagging studies where animals are netted or captured in some way to obtain a resighting. In this lobster reseeded experiment, tags were observed by divers while lobsters remained in-situ within dens. Consequently, we would expect this assumption to be fully valid. Assumption (5) was also met as survey periods were limited by diver bottom time to a period of up to 4 hours which is instantaneous relative to the time between samples of 48 hours.

We have some concern with assumption (4) as we know that it was violated, although to an unknown extent. Three tags were recovered from the seafloor within the release site. One of these remained attached to a shed exuvia (moult) so we know this was a case of tag loss. The other two tags were not attached to anything and may have been either the result of predation, or simply tag loss. In any case, the potential for tag loss to affect group comparisons is of concern because the moulting patterns of on-grown and control animals would be expected to differ. Future releases should aim to quantify tag loss of each group through double tagging some individuals with t-bar tags, which are retained through moults. Tag loss could then be included within the survival model (Hightower and Gilbert 1984; Nichols et al. 1994).

## 9.2 Study design and field methods

While a Jackson square as outlined above only requires a 2x2 grid, an 8x8 grid provides increased flexibility. Movement of antennal tagged lobsters can be tracked at a finer scale, and Jackson square calculations can be performed on squares at a range of scales to examine the precision of emigration estimates. The smaller size grid squares also aid efficient and thorough searching by divers.

An 8 x 8 block grid measuring 32 m by 32 m was deployed on the Glenvar Point reef. Two 32 m lengths of heavy trawl cable (1 1/2") were laid parallel at a distance of 32 m and the grid constructed between them with 6 mm rope. All grid squares were numbered with a cattle ear

tag attached by cable tie to the NE corner, allowing easy identification of grid position by divers.

On-grown lobsters for reseeded trials were chosen with carapace lengths in the range of 30 to 50 mm. Visible antennal tags were applied (see section 5.4). Lobsters were held a further 1 to 2 nights after tagging prior to release. Wild caught lobsters in the same size range were targeted, but tended to be larger and more variable in size than on-grown lobsters (Figure 22). As survival is assumed to increase with lobster size, this discrepancy would likely result in an underestimate of relative survival of on-grown lobsters. Because of the time required to apply tags, wild caught control lobsters were returned to the laboratory for a maximum of 2 nights prior to release.

Lobsters were carried to the release site in the wet-well of a research vessel. Once at the release site, lobsters were placed in a mesh bag, and released by divers at the centre of the Jackson square grid. Lobsters were released on 2 consecutive days, the second release being smaller than the first (Table 2).

Nine resighting surveys of the Jackson square site and adjacent reef areas were performed over a period of 29 days (Table 3). Note that for multi-strata modelling, survey returns from 10/9 and 11/9 were pooled to a single survey, to equate effort with that of 24/9 and 4/10. During surveys, two divers searched alternate grid rows, the survey taking approximately 60 to 80 minutes. The 4x4 grid squares were an appropriate size for searching unaided by further moveable quadrats. Searches were conducted using torches, and colour codes of tagged lobsters sighted in each square recorded along with the grid reference.

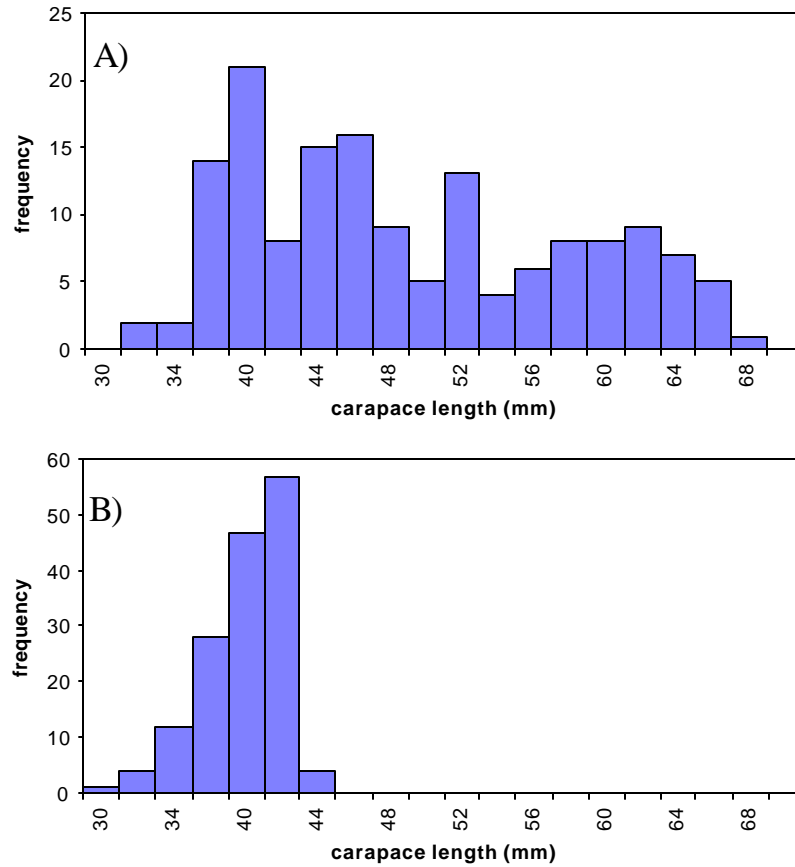

**Figure 22.** Length frequency distribution of A) wild-caught control lobsters and B) on-grown lobsters.

**Table 2.** Numbers of male and female antennae tagged juvenile rock lobsters from control and on-grown groups released each of two occasions.

A) Release 1

Treatment	Total released	Male	Female	F/M ratio
Wild	130	62	68	1.09
On-grown	364	170	194	1.14

B) Release 2

Treatment	Total released	Male	Female	F/M ratio
Wild	23	9	14	1.55
On-grown	63	27	36	1.33

**Table 3. Field activities performed on each day of reseeded experiment.**

R - release of lobsters; J - resighting survey on Jacksons square grid; A - resighting survey on reef adjacent to Jacksons square within a 5m border of the square; N - resighting survey of neighbouring reef to a distance of 800m from Jacksons square.

Date	Activity			
	R	J	A	N
6/9	✓			
7/9	✓			
8/9		✓	✓	
10/9		✓	✓	
11/9			✓	✓
13/9		✓	✓	
15/9		✓	✓	
17/9		✓	✓	
20/9		✓	✓	
24/9		✓	✓	✓
4/10		✓	✓	✓

### 9.3 Jackson square results

A fundamental assumption of the Jackson square technique appears to have been grossly violated. As explained by Manly (1985), the Jackson square design assumes movement is not so large that animals will move from one small square into another and then out of the site entirely between two samples. Distances moved by lobsters were considerably greater than predicted by sonic tracking results, and the chosen grid size proved inappropriate. As a result, emigration estimates from this technique would not be valid, and have not been included here.

### 9.4 Multi-strata modeling results

#### 9.4.1 Goodness of Fit testing

GOF tests were done in a two stage process. First, a parametric bootstrap test of the survival models from the rock lobster reseeded data was undertaken through program MARK using 100 simulations. These simulations assume that all model assumptions discussed in Section 9.1.3 are met. Most importantly, that every animal in the population (of each group) has the same recapture probability for each resighting occasion  $r_i$ , given that it is alive and in the survey area (Test 2 in RELEASE - see below); and every marked animal of each group has the same probability of surviving  $f_i$  from the  $i^{\text{th}}$  to the  $(i+1)^{\text{th}}$  sample (Test 3 in RELEASE - see below). The deviance of the model fitted to actual rock lobster reseeded data was then compared to that of the simulated data. Where the “real” deviance lay outside the extreme 5% of deviances of simulated data, the original data was considered to violate the GOF test (ie we chose an arbitrary level of  $\alpha=0.05$ ).

A limitation of the MARK parametric bootstrapping GOF test is that covariates are not permitted (this is a limitation of current theory, rather than simply a limitation of program MARK). This meant that the full and reduced multi-strata models could not be tested. To overcome this problem, the reseeded data was adjusted to remove the effect of strata. In effect, it was adjusted to the basic CJS format. It was considered that should GOF be demonstrated on the data in this form, GOF could be assumed for the multi-strata model given that this model only included additional movement parameters and these summed to 1 ( $\sum \Psi_i^{rs} = 1$ ); the validity of assumptions on the basic CJS component would have been tested. While this system provides a measure of GOF, it does not generate improved estimates of the over-dispersion quasi-likelihood parameter,  $c$ , from the simulation process. Improved estimates of  $c$ -hat can improve the model selection process in CJS models (ie identifying the most parsimonious of the reduced models).

Where the reseeded data appeared to violate the parametric bootstrapping test of GOF, the data was further explored using program RELEASE which tests GOF by partitioning the overall  $\chi^2$  test into its component elements. This allowed the source of lack of fit to be isolated.

#### 9.4.2 GOF Results

Parametric bootstrapping results indicated that data in the CJS format did not meet the assumptions of the model (Table 4). Deviances generated by the simulation process were less than the deviance of the full model using actual data (the full model used here was complete time and group dependence for both survival and resighting probability).

In addition to generating deviance estimates, the parametric bootstrapping procedure produced an estimate of 2.97 for  $c$ -hat, which can be used for correcting the Akaike Information Criterion (AICc) for over-dispersion (see Section 9.5). Although the model used here for GOF testing was not multi-strata, we applied the  $c$ -hat value of 2.97 generated by bootstrapping to the multi-strata model fits as a conservative measure. Adjustment of  $c$ -hat does not affect parameter estimates, but will change the standard errors and thus potentially alter the ranking of the most parsimonious model. When  $c$ -hat was adjusted for the reseeded multi-strata models, the ranking of the most parsimonious model did not change, although standard errors were increased. This confirms that in this case, incorporating the bootstrap  $c$ -hat estimate was a conservative approach with little risk of affecting major conclusions, despite the use of a CJS model in estimating  $c$ -hat.

**Table 4. Parametric bootstrap (PBS) deviance values from full data set with no strata effect.**

PBS results are bootstrap results from 100 simulations. The deviance value for the full model using actual data lies outside the range of simulated which implies assumptions of the model have not been met.

	PBS mean	PBS minimum	PBS maximum	Actual data
DEVIANCE	322.567	273.688	381.187	526.098

Following parametric bootstrapping, GOF testing proceeded to RELEASE analyses to partition the GOF test into its component elements (Table 5 and Table 6). These analyses

show clearly that there is a systematic bias and that the failure of the parametric bootstrap was not due to extra binomial variation (which would result in a scatter of significant results across the summary tables). Rather, the lack of fit could be clearly attributed to test 2 results from on-grown animals.

What does this imply ? Cooch and White (1999) suggest that where a systematic bias is observed it suggests that the starting model should be altered. The biological implications for the lack of fit appears to be inconsistent resighting of on-grown animals which was a problem we anticipated in selection of multi-strata models. On-grown animals appeared to move more than control animals and this movement was greater than we had expected based on initial tracking of sonic tagged animals (albeit under much lower density). When we observed that reseeded lobsters had moved to neighbouring reef, we adjusted our diver searches to include these regions. This additional searching was sporadic which we see reflected here in the test 2 results.

The implications for the modeling of this data set is that the movement of reseeded animals should be taken into account -which we have done through the use of multi-strata modelling. Unfortunately we are unable to test GOF of the multi-strata model so this solution remains untested, even if apparently reasonable. However, lending further support to this hypothesis is the observed highly significant effect of group on movement of animals away from the release site to neighbouring reef, with most movement by on-grown animals. The implication for the method of monitoring success of future releases is more clear. Greater effort should be made in searching a wide area on each survey occasion, even if this comes at the expense of frequency of surveys.

**Table 5. Summary Test 3 GOF results from RELEASE.**

Test 3 results tend to relate to the assumption of equal survival. These tests are relatively data-intensive so several have insufficient data for testing. Nonetheless, Test 3 results clearly tend to be non-significant at  $\alpha=0.05$ .

Group	Component	Chi-square	df	P-level	Sufficient Data
control	3.SR3	0.0000	1	1.0000	Yes
control	3.SR4	0.0000	1	1.0000	No
control	3.SR5	0.0000	1	1.0000	Yes
control	3.SR6	0.2726	1	0.6016	No
control	3.SR7	0.9390	1	0.3326	Yes
control	3.SR8	2.2260	1	0.1358	No
Control	3.SR	3.4376	6	0.7523	
control	3.Sm3	2.7195	1	0.0991	Yes
control	3.Sm4	0.7931	1	0.3732	Yes
control	3.Sm5	1.1007	1	0.2941	No
control	3.Sm6	2.9967	1	0.0833	No
control	3.Sm7	0.0000	1	1.0000	No
Control	3.Sm	7.6100	5	0.1791	
Control	TEST3	11.0476	11	0.4393	
on-grown	3.SR3	1.9048	1	0.1676	Yes
on-grown	3.SR4	3.4174	1	0.0644	Yes
on-grown	3.SR5	0.0000	1	1.0000	No
on-grown	3.SR6	0.3770	1	0.5392	No
on-grown	3.SR7	0.6726	1	0.4121	Yes
on-grown	3.SR8	4.3127	1	0.0378	Yes
On-grown	3.SR	10.6846	6	0.0986	
on-grown	3.Sm3	0.9200	1	0.3375	Yes
on-grown	3.Sm4	0.0000	1	1.0000	Yes
on-grown	3.Sm5	0.2777	1	0.5983	No
on-grown	3.Sm6	1.5335	1	0.2157	No
on-grown	3.Sm7	3.4073	1	0.0649	No
On-grown	3.Sm	6.1385	5	0.2930	
On-grown	TEST 3	16.8231	11	0.1132	
Both Groups	TEST 3	27.8706	22	0.1800	

**Table 6. Summary of Test 2 (Goodness of fit) results from RELEASE.**

Test 2 results tend to relate to the assumption of equal resighting probability. Note that a strong systematic bias is evident for resighting probability of on-grown animals on all survey occasions.

Group	Component	Chi-square	df	P-level	Sufficient Data
control	2.C2	6.5633	4	0.1608	Yes
control	2.C3	7.4651	5	0.1883	Yes
control	2.C4	2.9833	4	0.5606	Yes
control	2.C5	4.2057	3	0.2401	Yes
control	2.C6	4.1037	2	0.1285	Yes
control	2.C7	3.6776	1	0.0551	Yes
Control	TEST 2	28.9988	19	0.0660	
on-grown	2.C2	24.2523	5	0.0002	Yes
on-grown	2.C3	30.8243	4	0.0000	Yes
on-grown	2.C4	26.4132	4	0.0000	Yes
on-grown	2.C5	37.1218	3	0.0000	Yes
on-grown	2.C6	22.4534	2	0.0000	Yes
on-grown	2.C7	8.6500	1	0.0032	Yes
On-grown	TEST 2	149.7149	19	0.0000	
Both Groups	TEST 2	178.7137	38	0.0000	

## 9.5 Model selection

### 9.5.1 Models fitted and hypothesis process

An *a-priori* set of models were selected based on experimental design, effort and biologically probable outcomes. Models were fitted in a stepwise pattern, gradually eliminating parameters that did not improve model parsimony. Parsimony of models was assessed based on normalised Akaike weights (QAICc) as outlined by Anderson and Burnham (1998). The models fitted and the hypothesis behind each step is outlined in Table 7. Symbols used are the same as those used in section 9.1.2:  $f$  = survival;  $r$  = resighting probability;  $\Psi$  = movement between strata, with superscripts R and N denoting Release site and Neighbouring reef strata respectively; and model variables represented by  $g$  = group (on-grown/control),  $t$  = time (release (1) plus 8 resighting opportunities),  $s$  = strata (release site (R) and neighbouring reef (N)).

**Table 7. Multi-strata model fitting process.**

Hypotheses compare the model with the previous model in the list above that resulted in an increase in parsimony (ie the last model with “Y”(es) in the column labelled “More Parsimonious ?”). Models that resulted in a decrease in parsimony were not investigated further. Numbers in model formulae refer to survey or resighting opportunity number which were grouped to test the value of reducing parameters (and thus predict the effect of less intensive sampling in subsequent releases). The most parsimonious model contains a single parameter for survival, a resighting probability parameter for each survey in each strata (as this is partially dependant on dive team and visibility), three parameters for movement from the release site to neighbouring reef for each group (split into the first day, one for the next 5 surveys, and one for the last 2 surveys), and a separate parameter for movement of each group from neighbouring reef back to the release site (total parameters = 21).

No	Hypotheses	Model	QAICc	QAICc Weight	More Parsimonious ?
1	fully parameterised model	$\phi(g,t,s), p(g,t,s), \psi(g,t,s)$	1289.7	0.0000	
2	strata has no effect on survival (tests potential for problem of assumed Markovian survival)	$\phi(g,t), p(g,t,s), \psi(g,t,s)$	1235.3	0.0000	Y
3	group has no effect on resighting (ie groups have similar behaviour, seek shelter the same)	$\phi(g,t), p(t,s), \psi(g,t,s)$	1213.7	0.0000	Y
4	time has no effect on movement from strata N(eighbouring reef) back to R(elease site) although this varies with group ? (essentially recognises that this component of the model has little data, as few animals returned to release site, so probably contributes little to fit)	$\phi(g,t), p(t,s), \psi((g,t)^{R-N}(g)^{N-R})$	1193.7	0.0000	Y
5	group has no effect on movement from strata N to R although this varies with time (recognises lack of data for this component)	$\phi(g,t), p(t,s), \psi((g,t)^{R-N}(t)^{N-R})$	1205.9	0.0000	N
6	time has no effect on resighting probability although this varies between strata (no effect of dive team composition, visibility, change in lobster behaviour through experiment, variation in search area of strata N between surveys)	$\phi(g,t), p(s), \psi((g,t)^{R-N}(g)^{N-R})$	1236.0	0.0000	N
7	strata has no effect on resighting probability although this varies between time/surveys	$\phi(g,t), p(t), \psi((g,t)^{R-N}(g)^{N-R})$	1271.48	0.0000	N

(no effect of diver searching intensity differing between strata)

8	group has no effect on survival (survival of on-grown = survival of controls)	$\phi(t), p(t.s), \psi((g.t)^{R-N}(g)^{N-R})$	1176.4	0.0000	Y
9	group has no effect on movement from strata N to R (recognising that this component of the model has little data, tests similar hypothesis to model 5 but is not nested)	$\phi(t), p(t.s), \psi((g.t)^{R-N}(.)^{N-R})$	1179.5	0.0000	N
10	group has no effect on movement from strata R to N although this varies through time (control and on-grown animals move away from release strata in the same manner).	$\phi(t), p(t.s), \psi((t)^{R-N}(g)^{N-R})$	1186.5	0.0000	N
11	time has no effect on movement from strata R to N although this varies between groups (there is a constant rate of emigration from the release strata to neighbouring reef strata)	$\phi(t), p(t.s), \psi((g)^{R-N}(g)^{N-R})$	1188.8	0.0000	N
12	individual surveys could be grouped for survival modelling (3 groups : 1, 2 to 7, and 8; expected that lobsters would move to more premium habitat over days so that time was important, but surveys were intense so perhaps only the first period was critical ?)	$\phi(1,2-7,8),$ $p(t.s),$ $\psi((g.t)^{R-N}(g)^{N-R})$	1166.5	0.0000	Y
13	individual surveys could be grouped for movement modelling (3 groups : 1, 2 to 6, and 7 to 8; expected that lobsters would encounter preferred habitat over days so that time was important, but perhaps surveys could be less frequent ?)	$\phi(1,2-7,8),$ $p(t.s),$ $\psi((g.(1,2-6,7-8))^{R-N}(g)^{N-R})$	1147.4	0.0065	Y
14	individual surveys could be grouped for resighting modelling for strata N to group those samples where strata N was not surveyed: 1,3,4,5, and 6 (4 groups : 2; (1,3-6), 7 and 8)	$\phi(1,2-7,8),$ $p((t)^R(2,(1,3-6),7,8)^N,$ $\psi((g.(1,2-6,7-8))^{R-N}(g)^{N-R})$	1139.1	0.18102	Y
15	time has no effect on survival (tests the fitting of a single parameter - no group, strata or time effect)	$\phi(.),$ $p((t)^R(2,(1,3-6),7,8)^N,$ $\psi((g.(1,2-6,7-8))^{R-N}(g)^{N-R})$	1137.0	0.5015	Y

---

## 9.6 Results of multi-strata tag-recapture model

While the method used for model selection does not allow significance values to be attributed to tests between models, the QAICc values show that the final model is in excess of 2.5 times as well supported by the data as the next best model.

Selection of the most parsimonious model saw a reduction from 96 parameters (full model) to 21 parameters. Hypotheses used to derive the final model are intuitive, based on the sampling regime and relevant biological and environmental information.

Encounter probability on the release reef (Figure 23) varied daily, presumably due to natural variations in light levels, water clarity, and to survey team efficiency. Encounter probability on neighbouring reef (Figure 24), is partitioned by effort; this strata was sampled in surveys 2, 7 and 8 only. Movement away from the release site (Figure 25) was clearly highest by on-grown lobsters between release and survey 1, as observed by divers, but not detected in the Jackson square sampling data. Movement away from the release site between surveys 2 and 6 is modelled as a single parameter, being lower than survey 1, presumably as most lobsters redistributed away from the areas of highest density and settle into dens. Movement for the final 2 surveys was minimal.

Probability of lobsters moving from neighbouring reef back to the release reef (Figure 26) was low, but noticeably higher in on-grown than control lobsters. This reflects the larger magnitude directional movement away from the release site by on-grown lobsters.

Survival (Figure 27) was constant across surveys, strata and treatments. The estimated value of 0.95 should be considered conservative. The estimate is emigration biased; while the areas included as neighbouring reef in the surveys were extensive, it is likely that some lobsters have moved beyond this area. Tag loss, due to tag failure or lobsters moulting, has not been considered as the duration of this study did not allow for appropriate experiments to quantify tag loss. While evidence from holding lobsters in tanks suggests very low rates of tag shedding, 3 unattached tags and 1 lobster exuvia with a tag attached were found by divers during surveys. Emigration and tag loss will act to drive down the survival estimate.

These factors are unlikely to be wholly responsible for the survival estimate being below 1.0. Predation is also known to occur; large predatory reef fish were regularly seen in the study area, and gut contents of fish captured in the area included a lobster in the size range released in this study (section 7.2.2.1). Apparent predation on acoustic tagged lobsters in the Bicheno release (section 7.2.2.3) confirms that some degree of predation is likely.

Despite possible biases of the survival estimates generated by multi-strata modelling, the final estimate is impressively high with small error around the estimate indicated by the 95% confidence limits. Any survival estimate will be constrained by the upper and lower limits (100% or 0% survival) so an estimate with large errors will tend towards 50%. The fact that our estimate was close to 1 is encouraging on this basis.



**Figure 23.** Estimated probability of encountering on-grown or control lobsters over the 8 resighting surveys on the release reef.

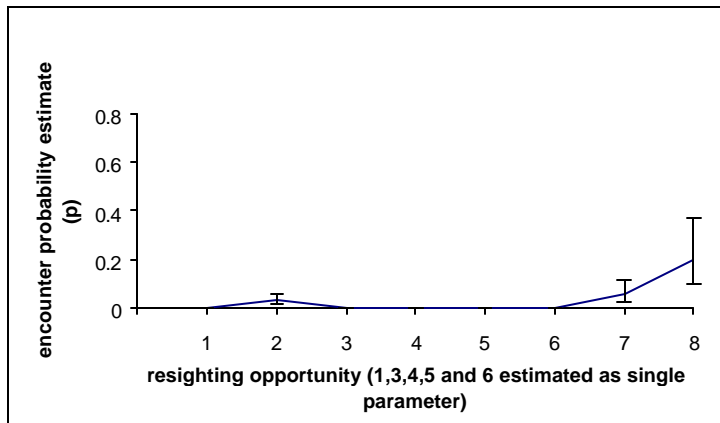

**Figure 24.** Estimated probability of encountering on-grown or control lobsters on neighbouring reef over the 8 resighting surveys. Note neighbouring reef was only searched during surveys 2, 7 and 8.

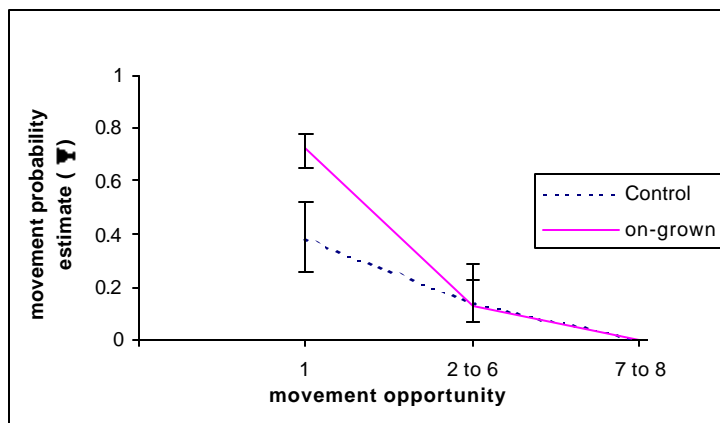

**Figure 25.** Estimated probability of control and on-grown lobsters moving from release reef to neighbouring reef. Movement of each treatment group was estimated by 3 parameters; movement on days 1, days 2 to 6, and days 7 to 8.

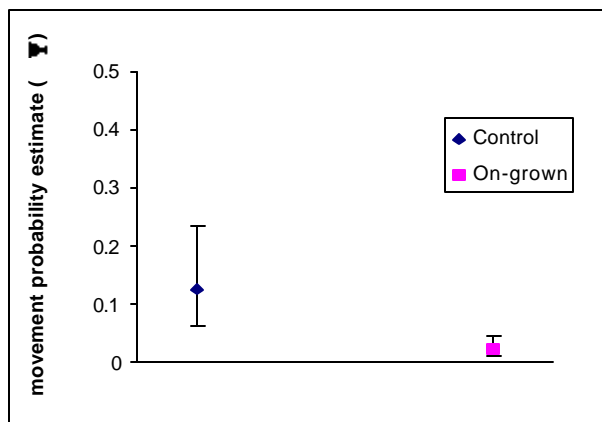

**Figure 26.** Movement by control and on-grown lobsters from neighbouring reef back to the release reef. Movement for each group was estimated by a single parameter.

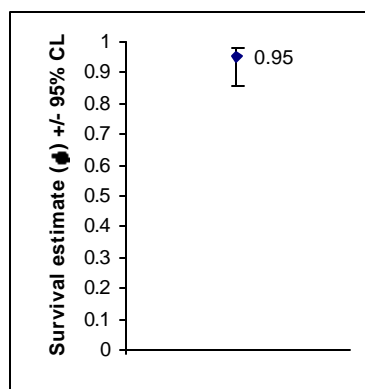

**Figure 27.** Survival estimate for control and on-grown lobsters estimated by a single parameter.

## 10. Benefits

The principle benefit of this preliminary project was the demonstration that measuring the survival of reseeded lobsters is possible and practical. Concerns relating to capture methods, tagging techniques and lobster movement, have been addressed. Appropriate modeling methods have been investigated, and recommendations for directions of future research are made. The risk associated with further research investment in this area has been reduced.

High preliminary survival estimates suggest there is merit in the use of reseeded to compensate for puerulus harvest. However, as the trial is not replicated, caution is urged in any extension of these results to other habitats.

Of further benefit to the wild fishery is an improved knowledge of movement and processes affecting the survival of juvenile lobsters. Testing the concept of reseeded is also relevant on a more general level as it could theoretically be applied to increase production in a range of fisheries.

The benefits to the aquaculture and wild fishery sectors of continuing this research to clearly establish protocols for successful reseeded are clear. For the aquaculture sector, successful reseeded provides a mechanism for overcoming the concerns of the lobster fishing industry about the harvest and on-growing of puerulus. By ensuring that the fishery is not harmed, even on a regional basis, it becomes possible to gain access to the harvest pueruli for aquaculture without creating conflict with existing users of the resource.

A fishery enhancement benefit is provided if the proportion of juveniles that survive reseeded is greater than would have survived in the wild. The benefit of enhancement can be focussed spatially to the areas where puerulus are harvested, or to areas with low levels of egg production. The magnitude of the benefit to both the fisheries and aquaculture sectors is ultimately proportional to the size of the aquaculture industry that develops through this system of compensation. The benefit to both sectors is greatest when the number of pueruli extracted is large.

Results are specifically relevant to southern rock lobster fisheries in other States, and more generally to other commercial Australian rock lobsters where on-growing of puerulus has been proposed (western, eastern and tropical rock lobster).

## **11. Further development**

This research has demonstrated that short term survival estimation for reseeded lobsters is both possible and practical. Results from multi-strata modeling are encouraging, and point to methods of producing more robust and widely applicable survival estimates.

The survey methodology employed in the current study was clearly less than ideal, primarily due to the limited information on juvenile lobster movement or behaviour available at the planning stage. Diver effort concentrated within the Jackson square area of the release reef was of limited value and wider area surveys were far more informative.

Likewise, the timing of surveys was not optimal. Useful information could be gained from more frequent sampling in the critical period to 2 days post release, when large scale movement by on-grown lobsters was recorded. Movement data from the final 7 surveys was modelled by 2 parameters only, suggesting that the temporal resolution of sampling in this period could be decreased. Effort liberated by less frequent sampling would be well used in increasing the search area, thereby decreasing any emigration bias that may be present. Further problems of bias associated with tag loss and moulting should be included in future designs (Hightower and Gilbert 1984; Nichols *et al.* 1994; Frusher *et al.* 1997). Multiple batch releases may also further improve parameter estimation in multi-strata modeling.

While the Jackson square layout as employed in this study was of limited use, the concept may still have value in further research. Calculations of emigration used in Jackson square are not limited to a square grid layout. If a release were to take place on an area of strip reef bounded by shore on one side, and sand on the other, 'small squares' (see 9.1.1) could be arranged end-to-end. In this way accurate estimates of numbers of lobsters moving beyond

the survey area could be obtained. No extra effort would be required on top of searches for multi-strata modeling, and the gains from eliminating emigration bias may be important.

A possible alternative approach to multi-strata is the modelling of survival with removals which requires a Brownian design (with multiple releases, rather than a single batch release). This would be viable if the search area was comprehensive and would allow the use of destructive sampling, such as with trammel nets. The incorporation of removals can also be useful for providing animals for associated research (eg for gut content testing). Sonic tagging results indicate that while most animals remain on reef near the release site, some unexpected movement can occur. Improved precision of survival estimates would be obtained by minimising the 'loss' of these animals into un-searched areas by deploying low trammel net barriers - animals captured could be simply treated as removals.

The applicability of survival estimates from the current research are limited, as the experiment is not replicated in space or time. The dichotomy between results from acoustic tracking at Bicheno and in the Derwent Estuary (sections 7.2.2.1 and 7.2.2.3) suggest that habitat may influence survival. We would also expect that habitat and behavioural variables would result in seasonal variation in survival.

Survival estimates from this short-term study can not be extrapolated to estimate long-term survival of reseeded juvenile lobsters. However, indications are that the survival and behaviour of on-grown lobsters will become equivalent to that of wild lobsters in a period as brief as the first 1 to 2 days post release. Evidence for this is four-fold. First, the multi-strata model showed no group effect on survival for the duration of the study. Second, divers observed on-grown and control lobsters cohabiting dens with untagged lobsters, and the avoidance behaviour of on-grown lobsters to divers appeared natural. Third, on-grown lobsters were feeding at similar rates to wild and control lobsters. Fourth, movement of on-grown lobsters was high initially but then reduced to small distances after a period of a few days.

To enable survival to be tracked through to recruitment to the fishery, future experimental releases could include animals with visible tags for diver surveys and long-term tags such as mini T-bar tags (see section 5.5) or micro-wire tags.

## **12. Conclusion**

This research has shown that accurate survival estimates for reseeded juvenile lobsters are achievable. Concerns relating to tagging methods, movement and ability to capture or resight lobsters have been addressed. New information on movement and behaviour of reseeded lobsters has led to the development of appropriate field and statistical methods for survival estimation. These methods can now be applied on a broader basis, encompassing variables such as habitat type, release method and lobster size.

The survival estimate of 95% for 1 month following reseeded in the Derwent Estuary is encouraging, and confirms the potential of reseeded as a tool for achieving 'biological neutrality' of puerulus harvest and for stock enhancement.

### 13. References

- Bannister, R.C.A. (1998). Lobster (*Homarus gammarus*) stock enhancement in the United Kingdom: hatchery-reared juvenile do survive in the wild, but cant they contribute significantly to ranching, enhancement , and management of lobster stocks. In: Gendron, L., 1998 (Ed). Proceeding of a Workshop on Lobster Stock Enhancement held in the Magdalen Islands (Québec) from October 29 to 31, 1997, *Canadian Industry Report of Fisheries and Aquatic Sciences* 244
- Brownie, C., Hines, E. J., Nichols, J. D., Pollock, K. H., and Hestbeck, J. B. (1993). Capture-recapture studies for multiple strata including non-Markovian transitions. *Biometrics* 49: 1173-1187.
- Burnham, K. P., and Anderson, D. R. (1998). Model Selection and Inference: A Practical Information Theoretic Approach. New York: Springer-Verlag.
- Cooch, E. and White, G., 1999. Program MARK: analysis of data from marked individuals. Documentation files available at: <http://canuck.dnr.cornell.edu/mark/>
- Cormack, R. M. (1964). Estimates of survival from the sighting of marked animals. *Biometrika*, 51: 429-438.
- Crear, B., Mills, D., Ritar, A., Thomas, C. and Hart, P., (1998). Rock lobster (*Jasus edwardsii*) aquaculture: annual report 1997/98. Tasmanian Aquaculture and Fisheries Institute Internal Report.
- Edmunds, M. (1995). The ecology of juvenile lobster, *Jasus edwardsii*. PhD thesis, University of Tasmania.
- Frusher, S. D., Kennedy, R. B. and Gibson, I. D. (1997). Precision of exploitation rate estimates in the Tasmanian rock lobster fishery using change-in-ratio techniques. *Marine and Freshwater Research* 48: 1069-1074.
- Hestbeck, J. B., Nichols, J. D. and Malecki, R. A. (1991). Estimates of movement and site fidelity using mark-resight data of wintering Canada geese. *Ecology* 72: 523-533.
- Hightower, J.E. and Gilbert, R.J. (1984). Using the Jolly -Seber model to estimate population size, mortality, and recruitment for a reservoir fish population. *Trans. Am. Fish. Soc.* 113: 543-611.
- Jackson, C.H.N. (1939) The analysis of animal population. *J. Anim. Ecol.* 8: 238-246.
- Jernakoff, P. and Phillips, B.F. (1986). Electromagnetic tracking of juvenile rock lobster. *Aust. J. Exp. Mar. Ecol.* 113: 125-144.
- Jolly, G. M. (1965). Explicit estimates from capture-recapture data with both death and immigration stochastic model. *Biometrika* 52: 225-247.
- Kennedy, R. (1986). Tagging - results of recent studies. In *Tasmanian Rock Lobster Seminar, 1986*, vol 25 (ed. S. Bear). Hobart: Department of Sea Fisheries Technical Report.
- Lebreton, J.D., Burnham, K. P., Clobert, J., and D.R. Anderson. (1992). Modeling survival and testing biological hypotheses using marked animals: a unified approach with case studies. *Ecological Monographs* 62: 67-118.

- Manly, B.F.J. (1985) A test of Jackson's method for separating death and emigration with mark-recapture data. *Res. Popul. Ecol.* 27: 99-109.
- Miller, D.L. (1982). Construction of shallow water habitats to increase lobster production in Mexico. *Proc. Gulf. Caribb. Fish. Inst.* 34: 168-179.
- Mintz, J.D., Lipcius, R.N., Eggleston, D.B. and Seebo, M.S. (1994). Survival of juvenile Caribbean spiny lobster: effects of shelter size, geographic location and conspecific abundance. *Mar. Ecol. Prog. Ser.*, 112: 255-266.
- Myer-Rochow, V.B. and Tiang, K.M. (1984). The eye of *Jasus edwardsii* (Crustacean, decapoda, Palinuridae): electrophysiology, histology and behaviour. *Zoologica* 134: 1-58.
- Nichols, J. D., Hines, J. E., Pollock, K. H., Hinz, R. L. and Link, W. A. (1994). Estimating breeding proportions and testing hypotheses about costs of reproduction with capture-recapture data. *Ecology* 75: 2052-2065.
- O'Dor, R.K., Andrade, Y. Webber, D.M. Sauer, W.H.H. Roberts, M.J. Smale M.J. and Voegeli, F.M. (1998). Applications and performance of Radio -Acoustic Positioning and Telemetry (RAPT) systems. *Hydrobiologia*, 371: 1-8.
- Sauer, W.H.H., Roberts, M.J. Lipinski, M.R. Smale, M.J. Hanlon, R.T., Webber D.M and O'Dor, R.K. (1997). Choreography of the squid's 'nuptial dance'. *Biol. Bull.* 192: 203-207.
- Seber, G. A. F. (1965). A note on the multiple recapture census. *Biometrika* 52: 249-259.
- Seber, G. A. F. (1982). Estimation of animal abundance and related parameters. Macmillan, New York.
- Tveite, S. And Grimsen, S. (1995). Survival of one-year-old artificially raised lobsters (*Homarus gammarus*) released in southern Norway. *ICES Mar. Sci. Symp.* 199: 73-77.
- van der Meeren, G.I. (1997) Preliminary acoustic tracking of native and transplanted European lobsters (*Homarus gammarus*) in an open sea lagoon. *Mar. Freshwater Res.* 48: 915 - 921.
- van der Meeren, G.I., Agnalt, A., and Jørstad, K.E. (1998). Lobster (*Homarus gammarus*) stock enhancement in Norway, Experiences from a large-scale release project from 1990 to 1997 In: Gendron, L., 1998 (Ed). Proceeding of a Workshop on Lobster Stock Enhancement held in the Magdalen Islands (Québec) from October 29 to 31, 1997, Canadian Industry Report of Fisheries and Aquatic Sciences 244.

## 14. Appendix 1 - Intellectual Property

No intellectual property was generated through this project that requires protecting.

## 15. Appendix 2 - Staff

Staff that have participated in this project are:

Mr Andrew Cawthorn (Technical Officer);

Dr Brad Crear (Research Fellow);  
Mr Stewart Frusher (Senior Research Fellow);  
Dr Caleb Gardner (Research Fellow);  
Mr Jac Gibson (Technical Officer);  
Mr Brett Hislop (Diver Officer);  
Mr Sam Ibbott (Research Assistant);  
Mr Craig MacKinnon (Junior Research Fellow);  
Mr David Mills (Junior Research Fellow);  
Mr Simon Wilcox (Technical Officer).

## 16. Appendix 3 - Bycatch species from trapping trials

### Fish

Conger Eel	<i>Conger verreauxi</i>
Draughtboard shark	<i>Cephaloscyllium laticeps</i>
Banded stingaree	<i>Urolophus cruciatus</i>
Blue throat wrasse	<i>Notolabrus tetricus</i>
Purple wrasse	<i>Notolabrus fucicola</i>
Shaw's cowfish	<i>Aracana aurita</i>
Red Cod	<i>Pseudophycis bachus</i>
Flounder	<i>Ammotretis sp.</i>
Brown striped leatherjacket	<i>Meuschenia australis</i>
Dragonet	<i>Bovichtus angustifrons</i>

### Invertebrates

Octopus	<i>Octopus maorum</i>
11 arm sea star	<i>Coscanasterias muricata</i>
Starfish sp.	<i>Pateriella regularis</i>
Velvet crab	<i>Nectocarcinus integrifons</i>
Red rock crab	<i>Plagusia chabrus</i>
Cancer crab	<i>Cancer novaezealandia</i>
Hermit crab	<i>Trizopaguris strigimanus</i>
Northern Pacific sea star	<i>Asterias amurensis</i>
Purple sea urchin	<i>Heliocidaris erythrogramma</i>

## **17. Appendix 4 - Log reports of areas surveyed for suitable tracking and release sites.**

**Secheron Point** - Under the wharf at CSIRO. The bottom is fairly homogenous, consisting of reclaimed ground. The rubble is unstable and silty with little macroalgae evident. Reports from Jeff Ross and Andrew Jones (CSIRO/TAFI) suggest this area may harbour high densities of juveniles at times and the substrate is suitable, however few juveniles were present at this time.

**Punchs Reef** - Off Tranmere. This reef is quite large and flat with only some areas of smaller rubble. Small numbers of juveniles are present, however they are generally slightly larger than our preferred size for this experiment (30 mm CL). Despite the low numbers of juveniles for collection of controls, this site may be suitable for tracking experiments as shelters can be easily searched.

**Alum Cliffs** - Two sites were investigated here and they both hold moderate numbers of small lobsters. The area is probably unsuitable for sonic tracking, however it may be good for casita/ trapping trials and hand collection of animals.

**Hinsby Reef** - The substrate here has boulders and harbours some juveniles between the boulders. The area is not suitable for much, but may be used to hand collect some samples to top up wild caught animals.

**Dixon's Reef** - Few lobsters found here although the reef does have rich algal communities. Little potential for future inclusion within this project.

**White Rock** - Healthy algal communities are present in this area, possibly as a result of the slightly higher exposure found here. Habitat is unsuitable for further work in this project. The substrate is quite structured and falls directly onto the sand with sand scouring on the fringing rocks.

**Opossum Bay** - The southern point of the bay has suitable habitat and in a dive of approximately 30 minutes duration 20 individuals were sighted. They were all solitary and in areas where collection was difficult. This area was recommended by Jeff Ross who also suggested a reef in approx 5m of water in the middle area of the bay. This area could be useful for hand collecting specimens to top up wild caught samples.

**Glenvar Bay** - The best site found yet for many of the applications required in the course of this project. The substrate consists of a smallish reef surrounded by sand and flat rock platform. The reef is small boulders and harbours much suitable habitat and moderate numbers of appropriately sized juveniles, as well as some slightly larger. The site is suitable for animal collection, tracking and casita testing.

**Pidgeon Holes** - Close to Glenvar Bay the Pidgeon Holes harbours large numbers of small animals in a complex substrate. A good spot for testing casitas, trapping trials and animal collection.

**Iron Pot** - A complex and large reef with large numbers of lobsters of varying sizes. It is unsuitable for many applications but could be used as a site to place long term casitas, and to dive for small animals to top up a sample.

**Betsy Island** - The inside of the island has some good reef for tracking animals with the sonic tags. The reef is low with many boulders fringing onto the sand. The reef is bordered on one side by the island, on another by sand, and the third side runs into a more structured and complex reef on the Eastern side of the island.

**Black Jack Rocks** - There is a larger low lying reef surrounding the rocks. The reef has discrete broken substrate interspersed by flat rock platform. There are few lobsters of any size in this area, and although it may be suitable for tracking, accessibility is a problem.

**Lauderdale Reef** - Needs further investigation. It is complex reef supporting a healthy algal community but may be prone to low visibility or badly swell affected.

**Lucas Point** - The area North of the Tinderbox reserve harbours large numbers of juvenile lobsters in a healthy ecosystem. The reef is extensive and complex making the lobsters hard to catch manually. This area is fantastic to test casita design and possibly to collect small numbers of lobsters for aquaria experiments.

**Ventenat Point** - Excellent bottom for larger lobsters, this area harbours many lobsters despite being heavily fished by recreational divers. The very complex nature of the reef makes it difficult to collect or track lobsters in this area, and there are few smaller lobsters.

**Quarries Point** - Very shallow and silty. Few lobsters. Unsuitable

**Swifts Point** - Very shallow and silty. Few lobsters. Unsuitable

**Sheepwash Bay** - A long reef runs along this shore. The reef is composed of rubble and boulders and is bounded by sand in about 7m and the shore on the other margin. The homogenous nature of the reef may allow it to be useful as a release point for lobsters to be tracked. There are few lobsters here but it seems good habitat..

**Simpsons point** - Similar to Sheepwash, however the reef becomes much shallower and flatter once around the point. Also the algal community reflects the lessening in exposure with more *Sargassum* and less *Ecklonia*.

**Green Island** - Dense algal communities in the shallows. The substrate is predominantly flat rock with some boulder areas fringing the deeper reef in about 9m. There are few lobsters and the area is unsuitable for tracking animals.

**Bligh Point** - The substrate is sandstone with many crevices and suitable habitat for juveniles, however there appear to be only a few juveniles. There are, however, animals from a range of

size classes represented in this area. There is a range of algae petering out at 9m where the reef runs to sand.

**Langfords Point** - is quite shallow and silty bottom with little macroalgae growing up into the water column. There are few lobsters here and it is not a suitable site for this project.

**The Shepherds** - Runs from Pear tree Bay to Snug Point and is similar to Bligh Point in both substrate and algal community. The habitat offers lobsters much protection although there are not high numbers of lobsters of any size here. The complex structure of the reef makes it difficult to conduct a comprehensive search.

**Tinderbox West** - Is very narrow sandstone reef which runs to sand quickly. There is limited habitat here and there appear to be few lobsters. This area is not suitable for inclusion within this project.

**Kellys Point** - A *Macrocystis* forest grows off this point into about 14 meters of water. The bottom is boulders providing more suitable habitat further South-East along the coast. There are some lobsters of all sizes in this area, but there are not high numbers of juveniles to enable easy collection.

**Cape de le Sortie** - Is dolerite and has large areas of smooth rock, and large boulders meaning there is little habitat in close, however this site is slightly deeper than many others dropping into 17 meters relatively quickly. The area of the reef fringing the sand has many smaller boulders and some rubble which provides a habitat suitable for smaller lobsters, however few lobsters of this size class were observed.

**Bull Bay** - The reef here is shallower than on the surrounding headlands and exhibits good habitat for juveniles but there appears to be no large numbers of lobsters in this area.